

SEL-710-5

Motor Protection Relay



Protect induction and synchronous motors with one relay

- Improve motor availability for production with patented, accurate thermal protection.
- Monitor and control motors directly with the 5-inch, 800 × 480 color touchscreen.
- Simplify your design by combining synchronous motor protection and power factor regulation in a single relay.
- Improve maintenance predictability by detecting broken rotor bars and early cable insulation breakdown.
- Increase safety for personnel and protect equipment with integrated arc-flash mitigation.



Functional Overview

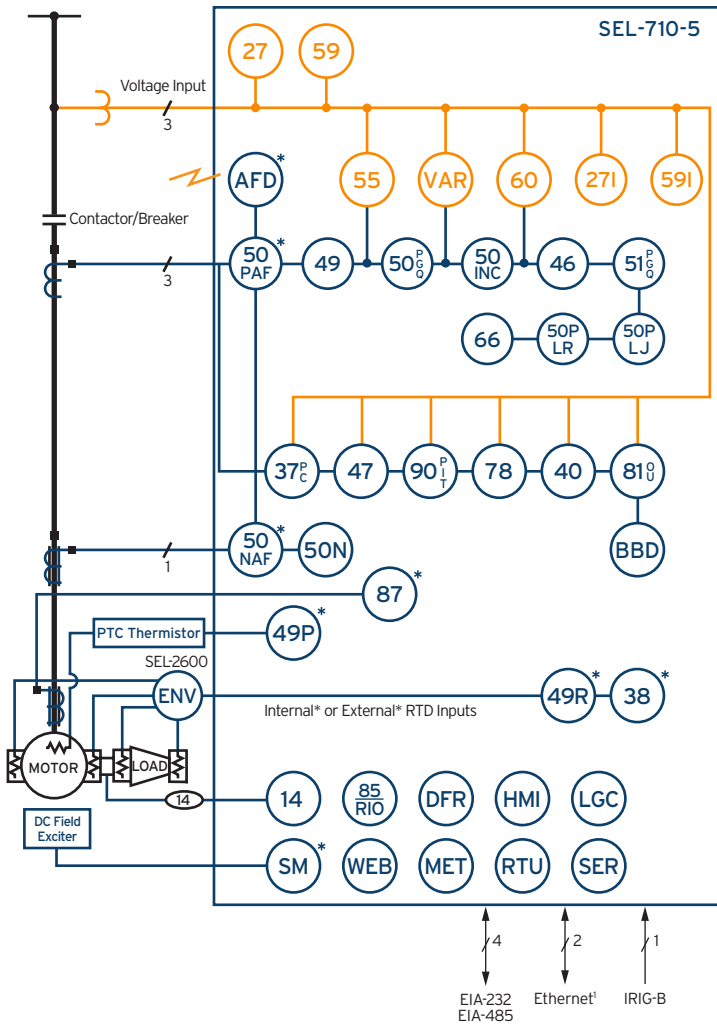

ANSI Numbers/Acronyms and Functions

14	Speed Switch
27	Phase Undervoltage
27I	Phase Undervoltage With Inverse Characteristic
37 (P,C)	Underpower/Undercurrent
38	Bearing Temperature*
40	Loss-of-Field
46	Current Unbalance
47	Phase Reversal
49P	PTC Overtemperature*
49R	Resistance Temperature Detector (RTD) Thermal*
49	Rotor and Stator Thermal Models
50 (P,G,Q)	Overcurrent (Phase, Ground, Neg. Seq.)
50INC	Incipient Cable Fault Detection
50NAF	Arc-Flash Neutral Overcurrent*
50PAF	Arc-Flash Phase Overcurrent*
50P LR	Locked Rotor
50P LJ	Load Jam
50N	Neutral Overcurrent
51 (P,G,Q)	Time-Overcurrent (Phase, Residual, Neg. Seq.)
55	Power Factor
59	Phase Overvoltage
59I	Overvoltage With Inverse Characteristic
60	Loss-of-Potential
66	Starts-Per-Hour
78	Out-of-Step
81 (O,U)	Over-/Underfrequency
87	Current Differential*
90 (P,I,T)	Load Control (Power, Current, Thermal Capacity)

Additional Functions

50/51	Adaptive Overcurrent
85 RIO	SEL MIRRORING BITS® Communications
97FM	Frequency Component Analyzer
AFD	Arc-Flash Detector ²
BBD	Broken Rotor Bar Detection
DFR	Event Reports—Motor Starts, Motor Operating Statistics
ENV	Optional SEL-2600 RTD Module
HMI	Operator Interface
LDP	Load Data Profiling
LGC	SELogix® Control Equations
MET	High-Accuracy Metering
RTU	Remote Terminal Unit
SDTM	Slip-Dependent AccuTrack™ Thermal Model
SER	Sequential Events Recorder
SM	Synchronous Motor Control and Protection ²
VAR	Reactive Power
VFD	Variable-Frequency Drive Support
WEB	Web Server

*Optional feature ¹Copper or fiber-optic

²Mutually exclusive optional features

Key Features

Multiple Applications

The SEL-710-5 Motor Protection Relay is a full-featured, multifunctional relay that provides complete ac induction and synchronous motor protection and control, including automatic starting. Install the SEL-710-5 for a wide variety of applications, such as fans, blowers, compressors, air handlers, pumps, conveyors, chippers, crushers, screeners, feeders, augers, and bucket elevators.

Induction Motor Protection and Starting

SEL-710-5 standard features include SEL's trusted current-, voltage-, and thermal-based motor protection with current differential elements. The powerful thermal model dynamically calculates motor slip to provide precise temperature tracking with less time required between restarts and to allow more time during the start sequence for the motor to reach its rated speed before tripping.

Synchronous Motor Protection and Starting

The SEL-710-5 provides two levels of field over- and undervoltage, field over- and undercurrent, and field resistance protection as options. It provides automatic synchronization by applying the dc field voltage to the motor field at the correct slip frequency and rotor angle to lock the motor to synchronous speed. It also includes out-of-step and loss-of-field protection.

Asset Monitoring

Track the operating characteristics of your motor and accompanying devices with the built-in asset-monitoring capability. The SEL-710-5 can track items, such as vibration, motor start current, motor start times, motor stop times, broken rotor bars, incipient faults, and excessive wear on molded case circuit breakers, in one easy-to-read report via the ASCII terminal or the touchscreen display. This enables you to reduce production losses from unexpected equipment failures and to lower maintenance costs by switching to predefined maintenance schedules. With the 97FM elements, you can detect selectable frequency components in current, voltage, and power quantities.

Arc-Flash Mitigation

Overcurrent-supervised arc-flash mitigation provides secure arc-flash tripping by operating when arc-flash and overcurrent conditions occur together. This important feature improves worker safety in areas where high fault current and high incident energy arc-flash events are possible.

Broken Rotor Bar Detection

The broken rotor bar feature uses current signature analysis (CSA) to detect broken rotor bars. Early detection reduces maintenance costs and helps prevent associated thermal and mechanical damage that contributes to catastrophic motor failure.

Flexible Communications

Advanced protocols support communications using legacy and modern supervisory and control systems. These protocols include IEC 61850 Edition 2, EtherNet/IP, the software-based IEEE 1588 Precision Time Protocol (PTP), IEC 60870-5-103, the Parallel Redundancy Protocol (PRP), DNP3, Modbus TCP/IP, Modbus RTU, Telnet, the File Transfer Protocol (FTP), the Simple Network Time Protocol (SNTP), MIRRORING BITS communications, and ASCII. In addition, the IEC 61850 test mode in the SEL-710-5 enables in-service testing, which reduces commissioning time.

Reliable Rugged Hardware

The SEL-710-5 operates in extreme conditions, with an operating temperature range of -40° to $+85^{\circ}\text{C}$ (-40° to $+185^{\circ}\text{F}$). It is designed and tested to exceed applicable standards, including those for withstanding vibration, electromagnetic interference, and adverse environmental conditions. A conformal coating option for the printed circuit boards provides an additional barrier against airborne contaminants, such as hydrogen sulfide, chlorine, salt, and moisture. In addition, the SEL-710-5 is ATEX-certified and Underwriters Laboratories (UL) Class I, Division 2-certified for use in hazardous and potentially explosive environments.

Incipient Cable Fault Detection

Cable insulation degrades over time. The incipient cable fault detection element can monitor for self-extinguishing, half-cycle overcurrent events that precede typical cable insulation failure. Monitoring the number of incipient faults can provide an early warning of cable insulation breakdown for preventative maintenance.

Product Overview



Power supply options include 24–48 Vdc or 110–250 Vdc/110–240 Vac.

Port options include demodulated IRIG-B for precise-time input or a PTC input to protect against overcurrent conditions.

A wide variety of communications protocols and media provide flexibility to communicate with other devices and control systems.

Accelerate firmware downloads via the Ethernet port.

MIRRORED BITS communications provides fast and reliable relay-to-relay communication.

Card slots include positions for optional I/O, arc-flash detection (AFD), or synchronous motor inputs/differential current inputs.

CT and PT inputs are located on one card, allowing for more I/O in other slots.

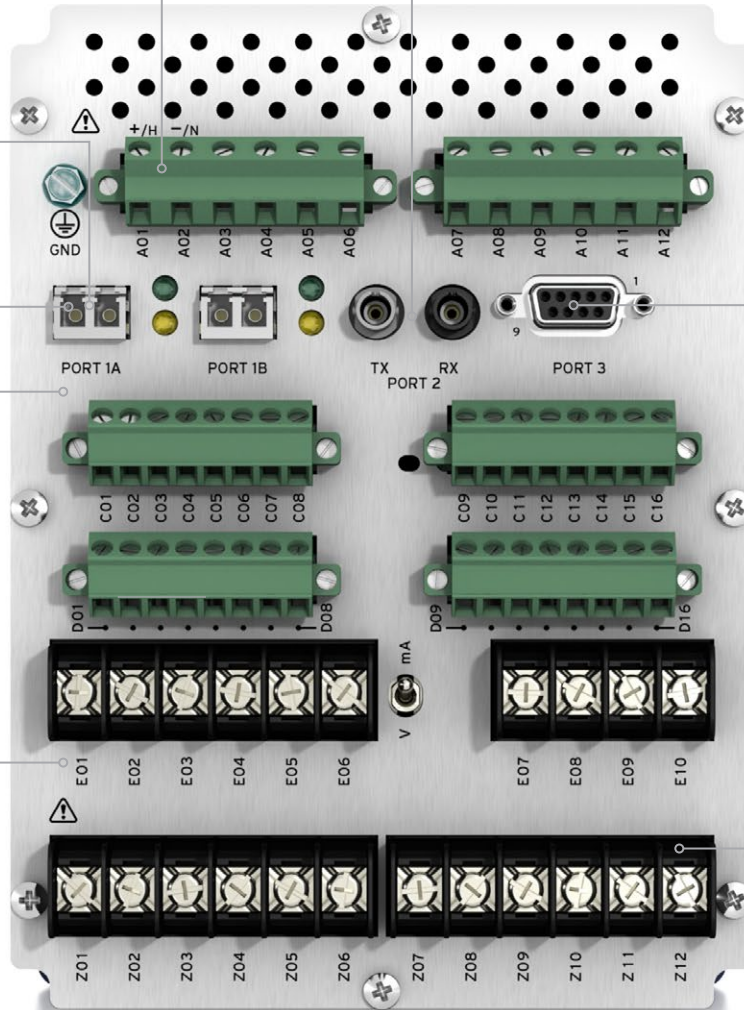

Touchscreen Overview

The 5-inch color display with a resolution of 800 × 480 offers direct navigation via a capacitive touchscreen.

The full keyboard facilitates easy adjustment of settings.

Folders and applications provide quick access to bay screens, metering and monitoring data, reports, settings, and more.

The home pushbutton allows you to easily return to the default home screen.

The front panel is available in English or Spanish.

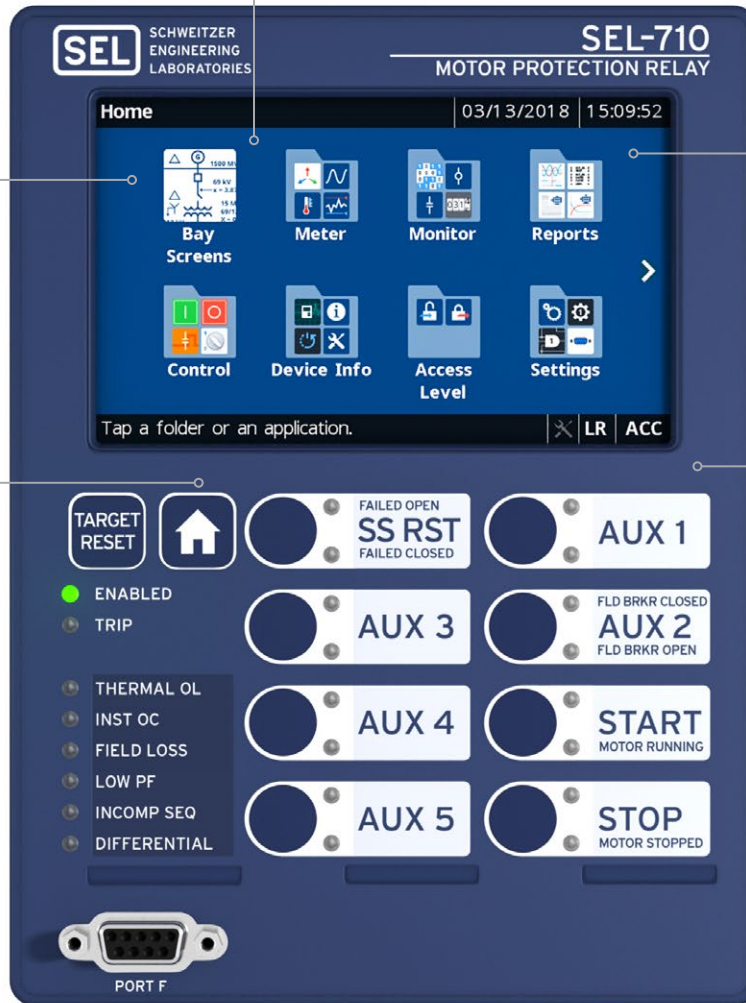

Touchscreen Display Features and Functions

The SEL-710-5 5-inch, 800 × 480 color touchscreen display provides a one-line diagram mimic display for bay control and monitoring. You can view metered quantities, phasor diagrams, relay settings, event summaries, target statuses, and SER data.

Motor Control

The color touchscreen lets you control a motor via a custom bay screen or the built-in Start Motor and Stop Motor applications in the Control folder.

To control a motor, simply tap the Control folder on the home screen, and then tap Start Motor or Stop Motor.

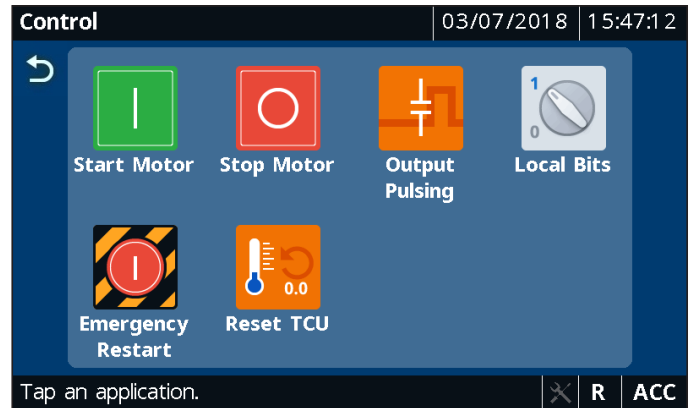

Next, enter your Level 2 password and tap Submit. The onscreen keyboard allows you to quickly and easily enter passwords, search for Relay Word bits, and enter settings when necessary.

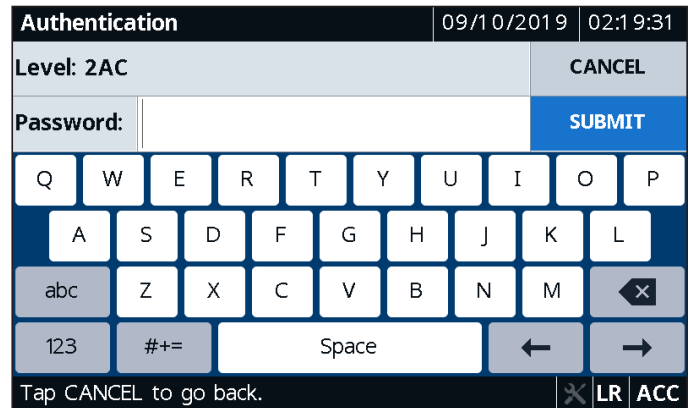

When the screen prompts you to confirm the action, tap Yes.

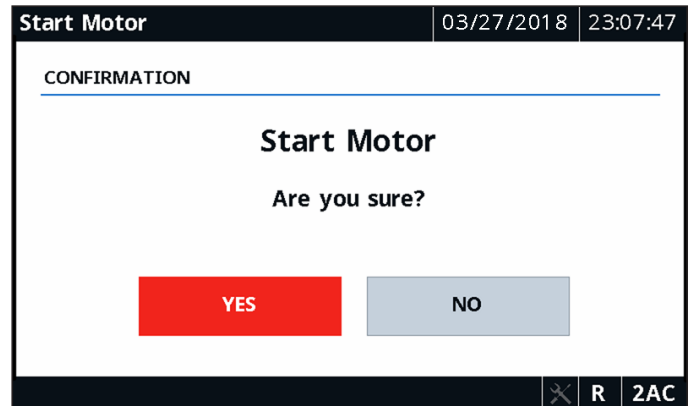

Meter Fundamentals

View the real, reactive, and apparent power of each phase in your system, and monitor the power factor information to determine if the phase current leads or lags the phase voltage.

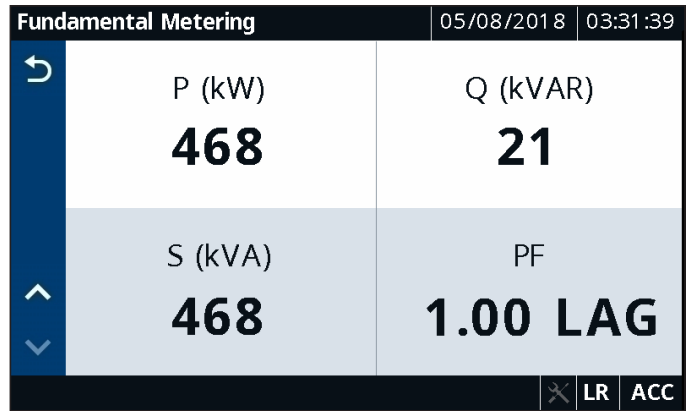

Meter Phasors

View a graphical and textual representation of the real-time voltages and currents in a power system during balanced and unbalanced conditions. By analyzing the phasors, you can determine power system conditions.

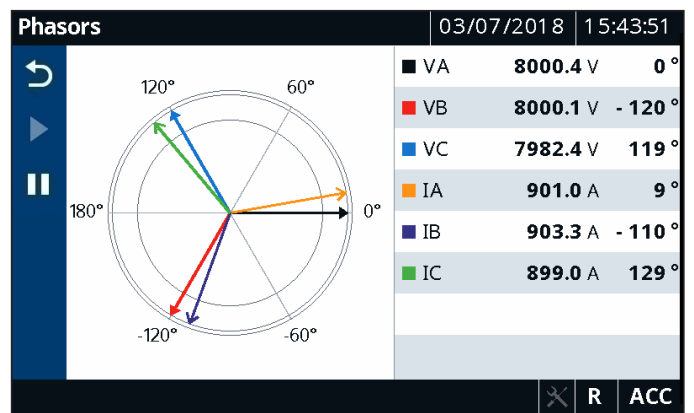

Motor Operating Statistics

View critical motor behavior data to optimize motor performance and extend motor life. Operating statistics for the protected motor include motor running time, stopped time, percent time running, motor starts, emergency starts, and others.

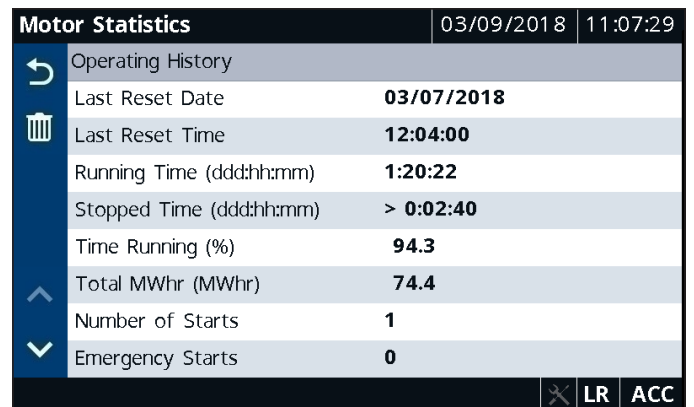

Vibration Monitoring

View critical motor vibration data to identify potential defects and respond before motor failures occur. The display provides intuitive graphical feedback to enable timely operator response.

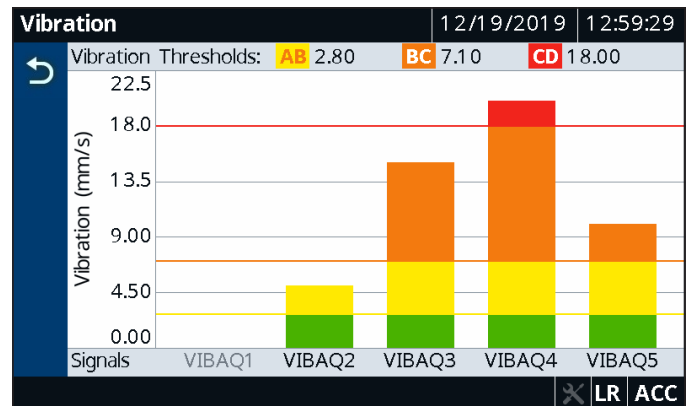

Applications

Synchronous Motor Protection

Select the SEL-710-5 with the synchronous motor protection option to start and protect synchronous motors. You can monitor field voltage and current and effectively respond to loss-of-field, field resistance, out-of-step, power factor, and reactive power issues.

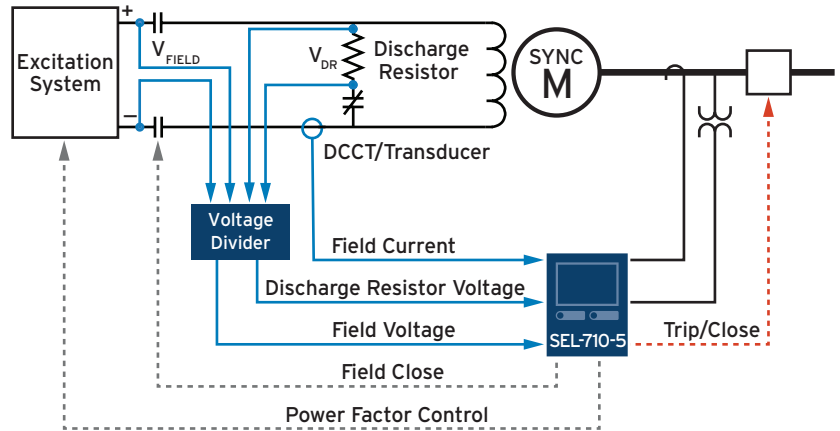

In this brush-type synchronous motor application, the SEL-710-5 connects directly to the excitation system to control the power factor.

Arc-Flash Detection

AFD-based protection is fast, responding in a few milliseconds with high-speed, high-current interrupting output contacts. This fast response, supervised by phase overcurrent elements, provides high-speed and secure arc-flash protection that improves personnel safety and reduces equipment damage. Arc-flash mitigation options in the SEL-710-5 offer either four or eight AFD inputs capable of reading both point and loop sensors.

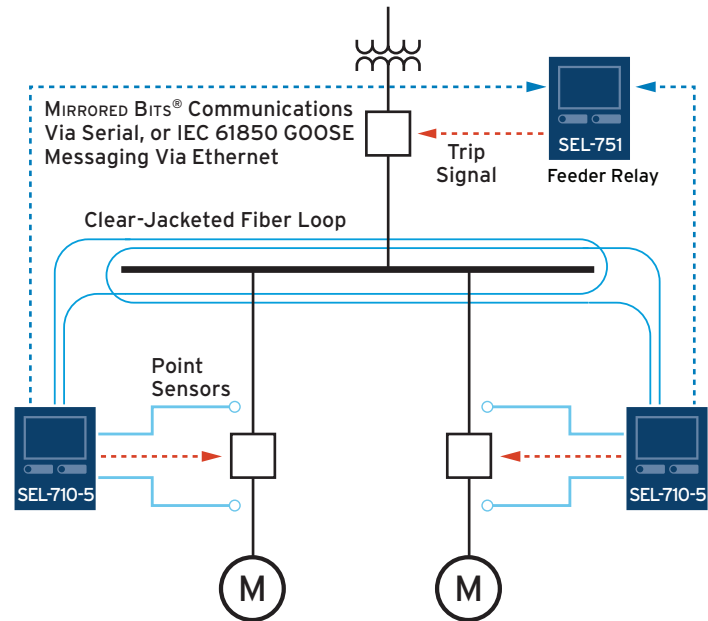

Overcurrent-supervised arc-flash detection and advanced communications combine to improve safety and power system reliability.

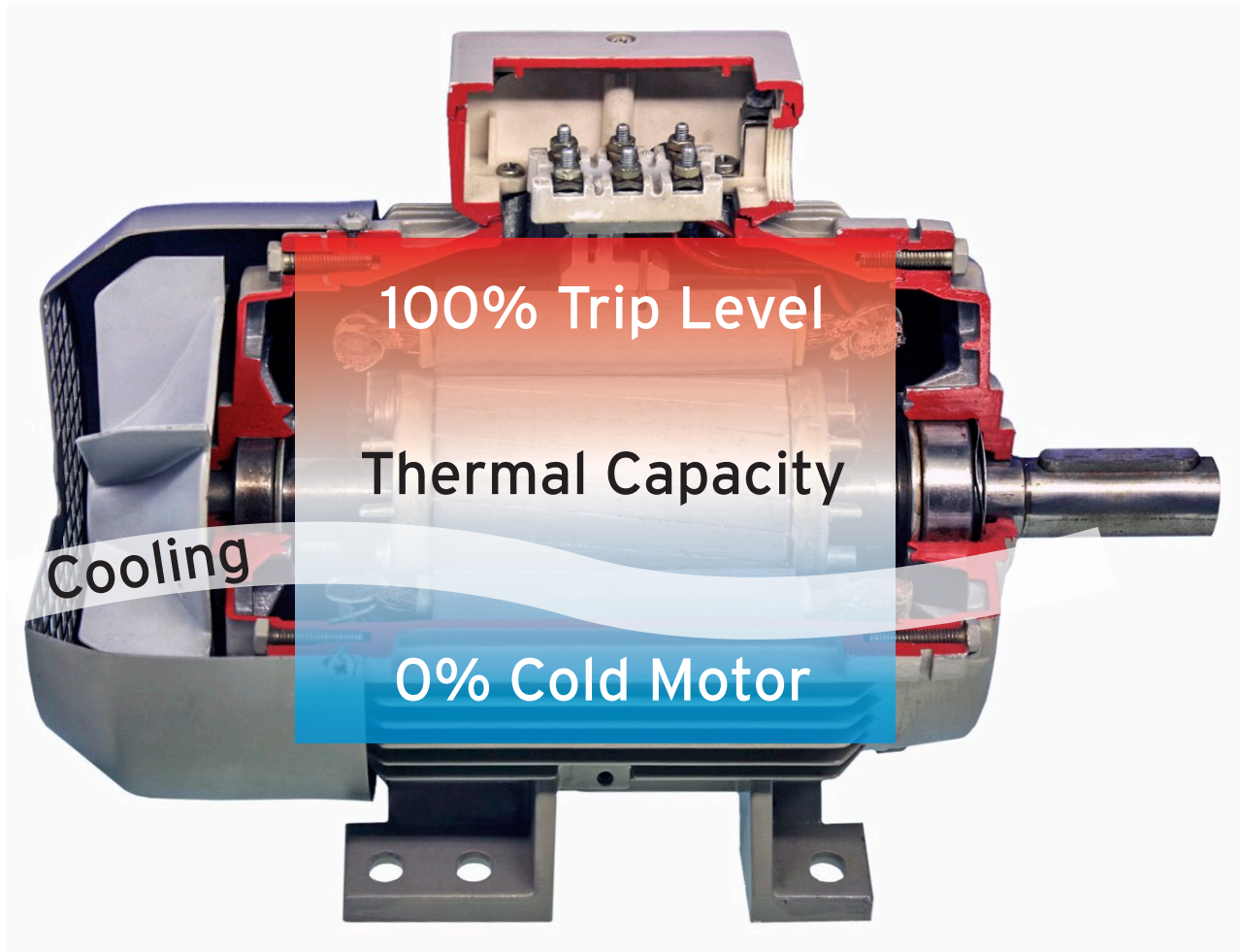

Thermal capacity is affected by positive-sequence heating, negative-sequence heating, and motor cooling.

Motor Thermal Overload Protection

The SEL-710-5 provides locked-rotor, running overload, and negative-sequence current unbalance protection. It accurately tracks the heating effects of load current and current unbalance during the motor's operating conditions (starting and running) using the AccuTrack Thermal Model.

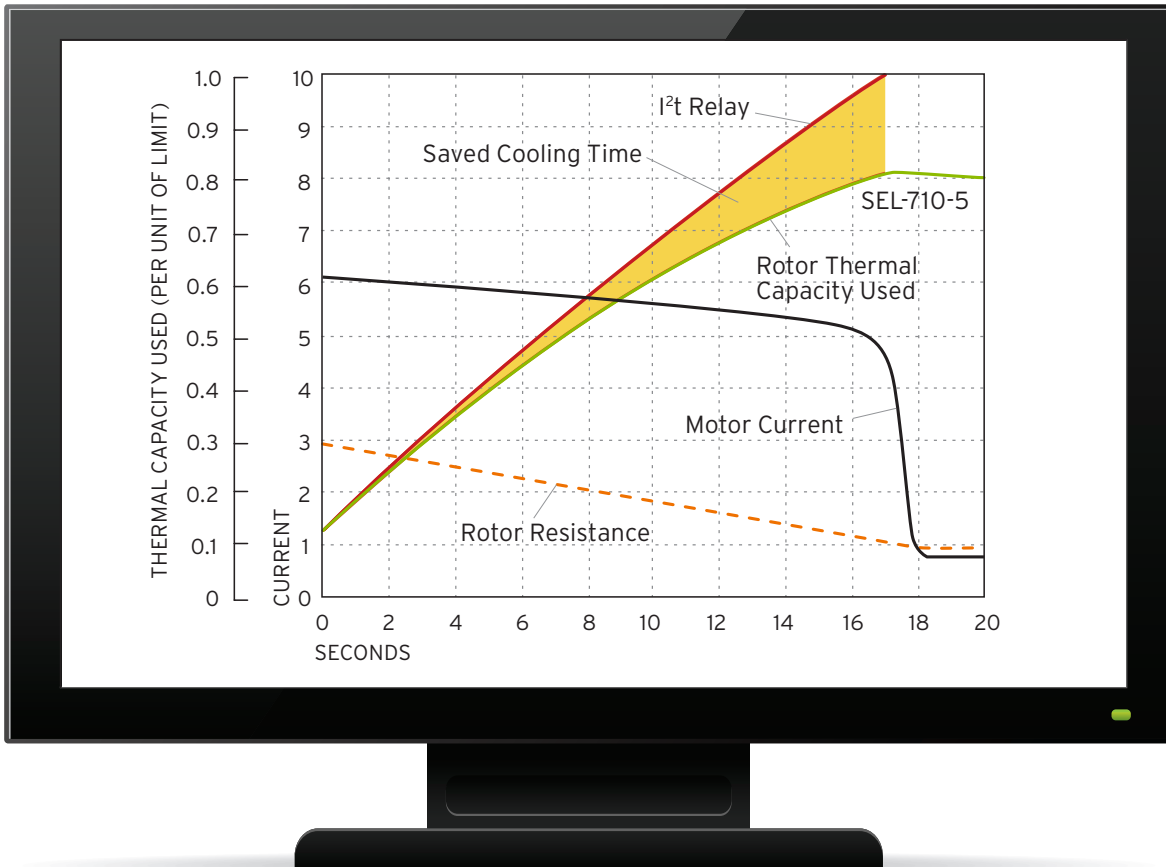

Accurate thermal modeling maximizes motor availability while providing excellent protection from damage.

AccuTrack Thermal Model

Apply the SEL-710-5 to dynamically calculate motor slip and precisely track the rotor thermal capacity used. The AccuTrack Thermal Model uses this information to reduce the time between starts, and it also gives the motor more time to reach its rated speed before tripping.

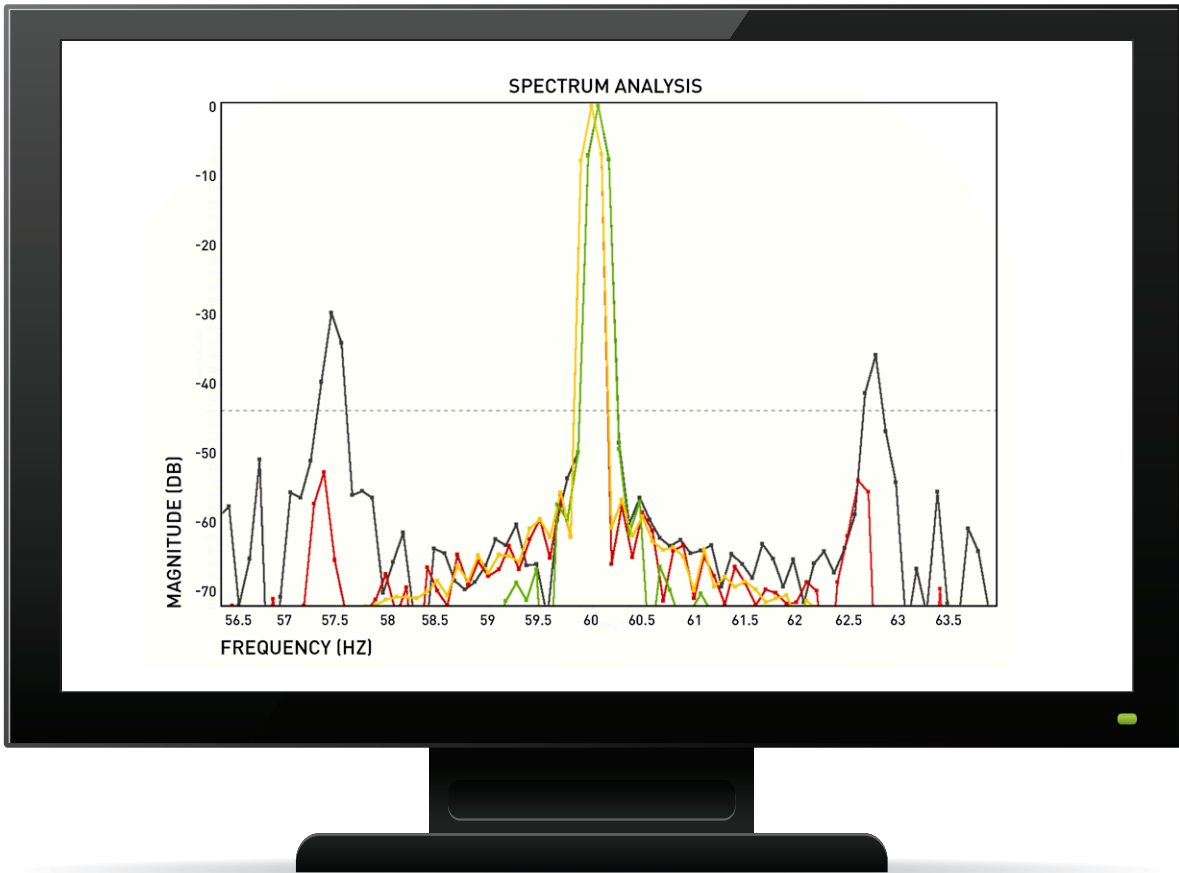

Spectrum of a running motor with three broken bars.

Broken Rotor Bar Detection

The BBD function determines if there are broken rotor bars by calculating the relative magnitudes of the signals at the sideband frequencies caused by a broken bar, with respect to the signal magnitudes at the system frequency. Using the CSA algorithm, the SEL-710-5 identifies rotor failures independent of the motor characteristic.

The BBD feature includes:

- A Fourier transform function that calculates the frequency spectrum of stator currents and voltages to provide accurate detection in cases with sideband frequencies.
- A history report with the date and time of the BBD operations along with the maximum sideband magnitude and associated frequency.
- A compressed harmonic meter report for voltages and current.
- A spectrum graphing feature in acSELERATOR QuickSet® SEL-5030 Software.

Simple Integration and Configuration

Optional Cards

Serial communications (EIA-232/EIA-485)

3 digital inputs (DI), 4 digital outputs (DO)
1 analog output (AO)

4 DI, 4 DO—electromechanical

4 DI, 4 DO—high-speed, high-current interrupting

4 DI, 3 DO (2 Form C, 1 Form B)

8 DO—electromechanical

8 DI

14 DI

8 analog inputs (AI)

4 AI, 4 AO

10 RTD inputs

4 AFD inputs, 3 current differential inputs

8 AFD inputs

Synchronous motor inputs and 3 current differential inputs



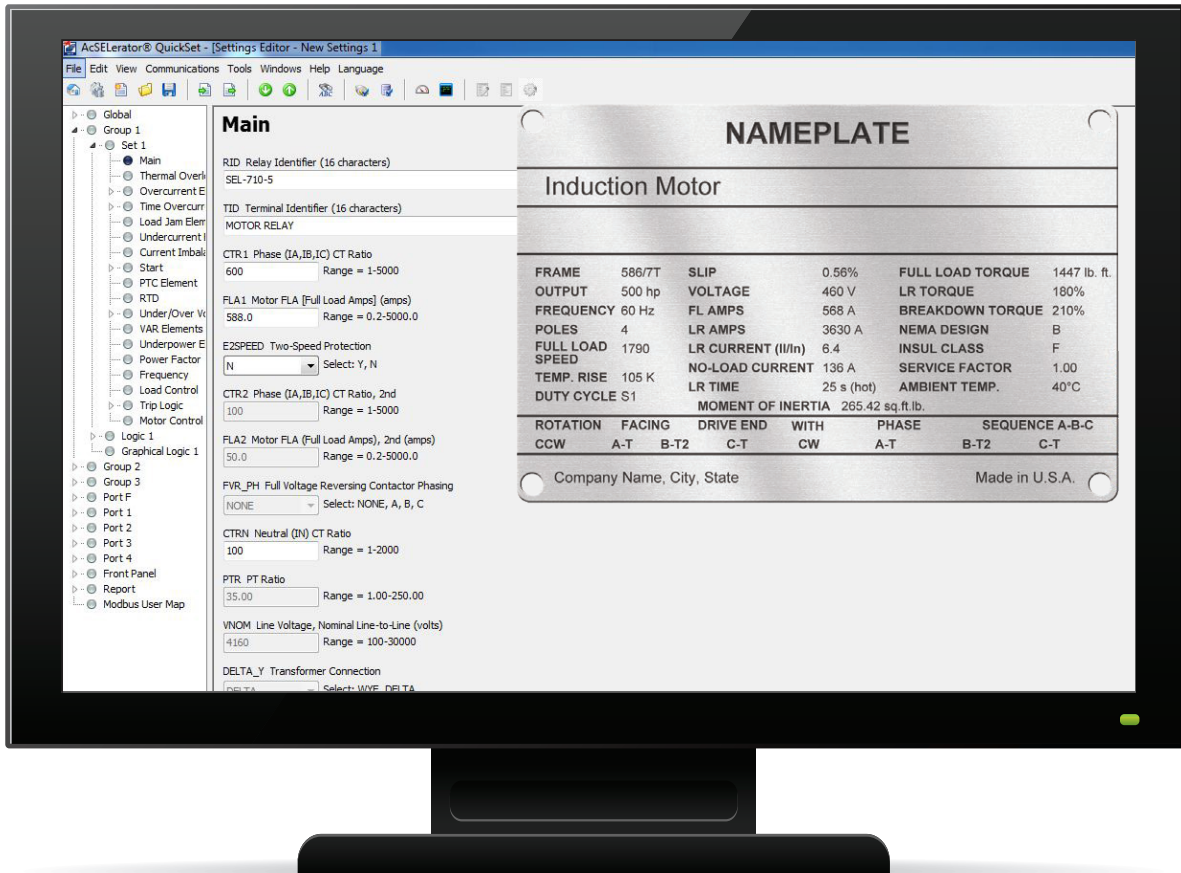

Use QuickSet to set the SEL-710-5.

Manage Relay Settings

Use QuickSet to set the SEL-710-5 and leverage convenient features to simplify the setting process. All relay settings are visible; however, the settings that are not related to your active hardware and configuration are shaded and cannot be selected or modified.

To enable AccuTrack for motor protection, select from either the Ratings or Curve methods to set the relay. Once the method is selected, only the settings that are relevant to that method can be modified to fit your application.

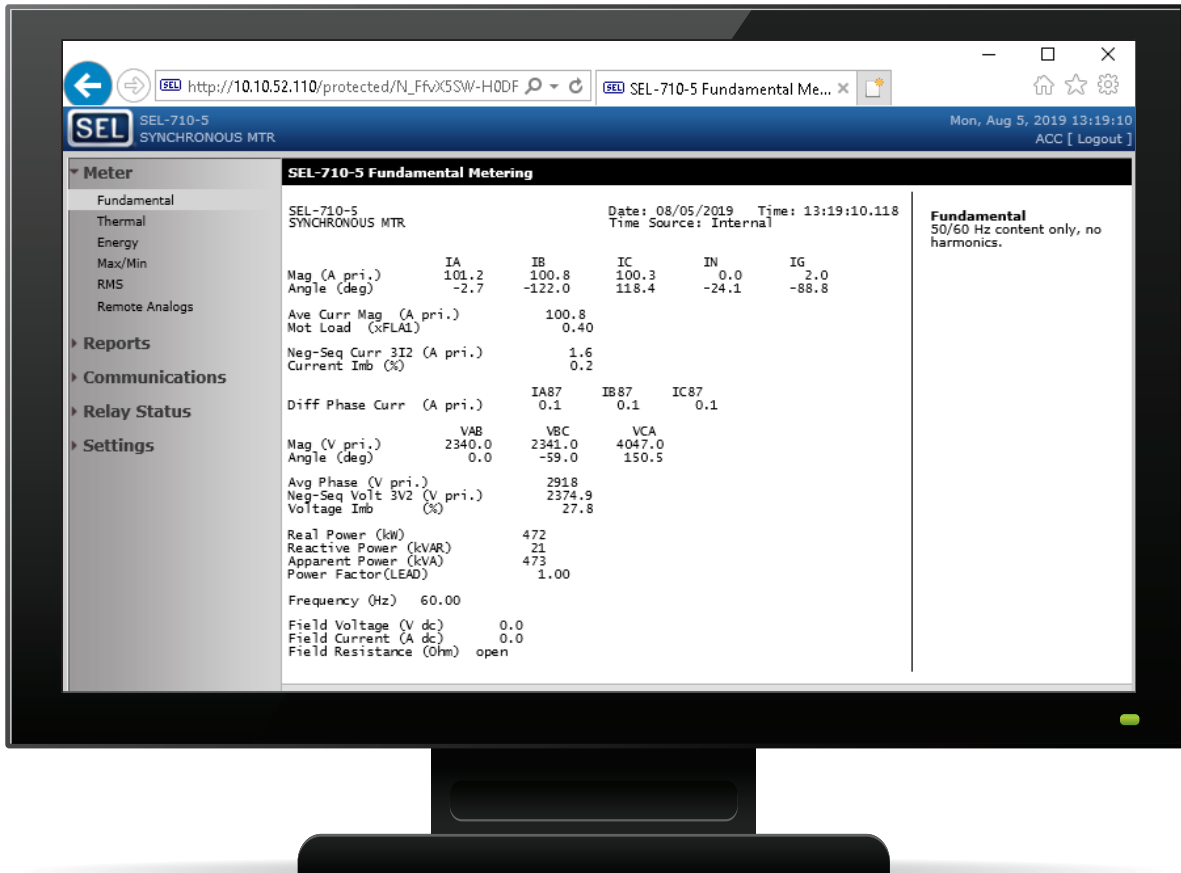

Use the built-in web server to access SEL-710-5 information.

Integrated Web Server

Access basic SEL-710-5 information on a standard web browser with the built-in web server. You can view the relay status, SER data, metering information, and settings and can download event reports with easy access within a local network. For increased security, web server access requires a relay password and the information is limited to a read-only view. You can also upgrade the relay firmware through the web server.

SEL-710-5 Specifications

General	
Displays	2-line × 16-character LCD 5-inch color touchscreen display, 800 × 480 pixels
AC Current Inputs	5 A or 1 A phase and 5 A, 1 A, or 2.5 mA (high sensitivity) neutral, depending on model
AC Voltage Inputs	300 Vac continuous, 600 Vac for 10 seconds
Output Contacts	The relay supports Form A, B, and C outputs.
Optoisolated Control Inputs	DC/AC control signals: 250, 220, 125, 110, 48, or 24 V As many as 26 inputs are allowed in ambient temperatures of 85°C (185°F) or less. As many as 34 inputs are allowed in ambient temperatures of 75°C (167°F) or less. As many as 44 inputs are allowed in ambient temperatures of 65°C (149°F) or less.
Frequency and Phase Rotation	System frequency: 50, 60 Hz Phase rotation: ABC, ACB Frequency tracking: 15–70 Hz (requires ac voltage inputs)
Arc-Flash Time-Overlight® Elements (TOL1–TOL8)	Pickup time: 2–5 ms Dropout time: 1 cycle
Communications Protocols	SEL (Fast Meter, Fast Operate, and Fast SER), Modbus TCP/IP, Modbus RTU, DNP3, FTP, IRIG-B, Telnet, SNTP, EtherNet/IP, software-based IEEE 1588 PTP, IEC 61850 Edition 2, IEC 60870-5-103, PRP for dual-Ethernet models, and MIRRORRED BITS communications
Language Support	English and Spanish
Power Supply	110–250 Vdc or 110–240 Vac Input voltage range: 85–300 Vdc or 85–264 Vac 24–48 Vdc Input voltage range: 19.2–60 Vdc
Operating Temperature	–40° to +85°C (–40° to +185°F) Note: Front-panel display contrast is impaired for temperatures below –20°C (–4°F) and above +70°C (+158°F).
Certifications	To view certifications for the SEL-710-5, please visit selinc.com/company/certifications .

SCHWEITZER ENGINEERING LABORATORIES

Making Electric Power Safer, More Reliable, and More Economical
+1.509.332.1890 | info@selinc.com | selinc.com

© 2020 by Schweitzer Engineering Laboratories, Inc.
PF00313 • 20200521

