

# SEL-700G

## Generator Protection Relay



## Comprehensive protection for large, medium, and small generators

- Provide primary and backup generator protection with current, voltage, frequency, distance, power, and out-of-step elements.
- Achieve 100 percent stator ground protection with full winding coverage.
- Use the automatic synchronizer and event reports to analyze generator startup, shutdown, or system faults.
- Quickly configure, monitor, and control your system using the new touchscreen display.



# Functional Overview

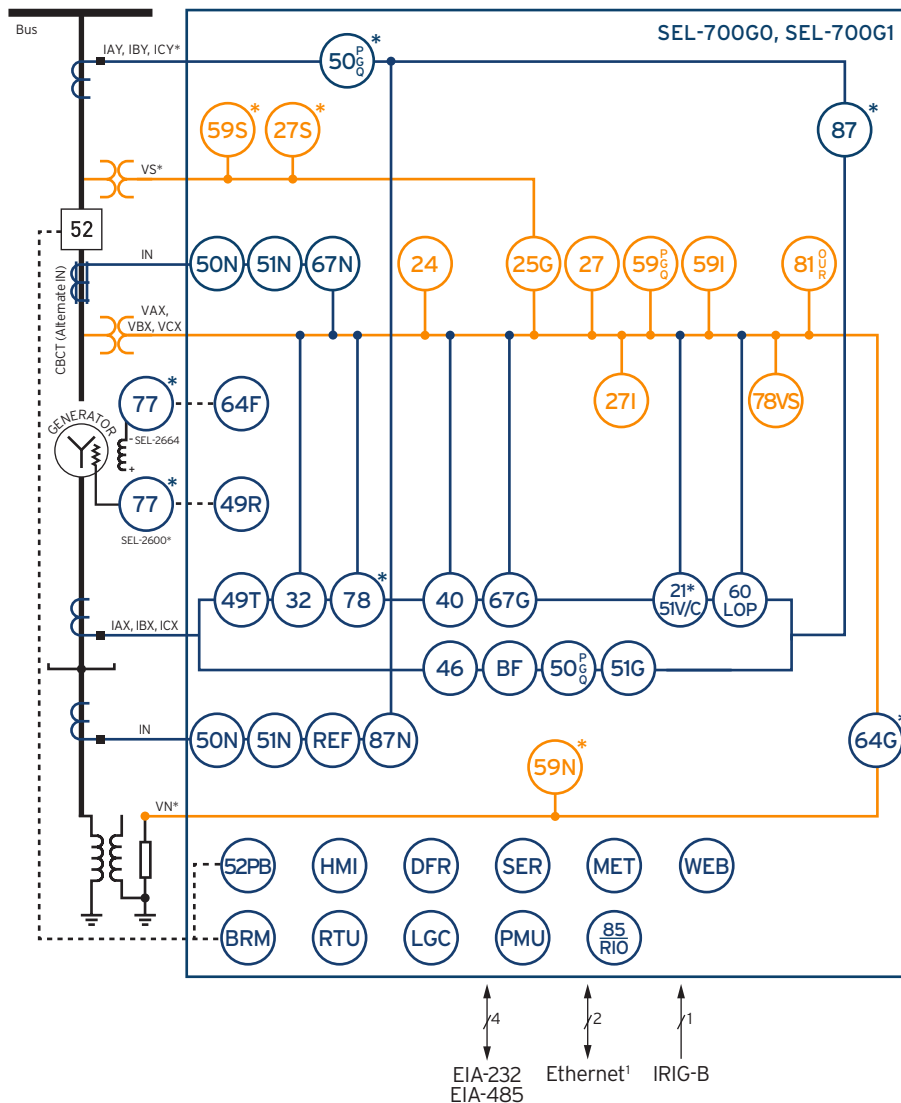

## Model Comparison Table

You can customize the SEL-700G for specific applications by selecting preconfigured model options.

Model	Application
SEL-700G0 or SEL-700G0+	Basic generator protection
SEL-700G1 or SEL-700G1+	Full generator protection
SEL-700GT	Intertie protection
SEL-700GT+	Intertie and generator protection
SEL-700GW	Basic dual-feeder protection

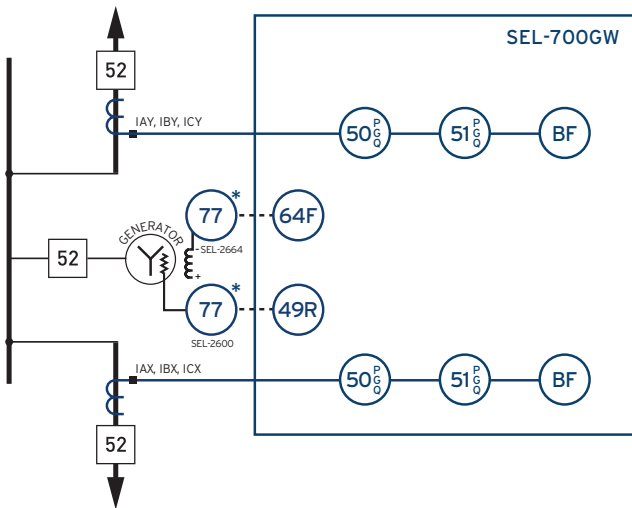
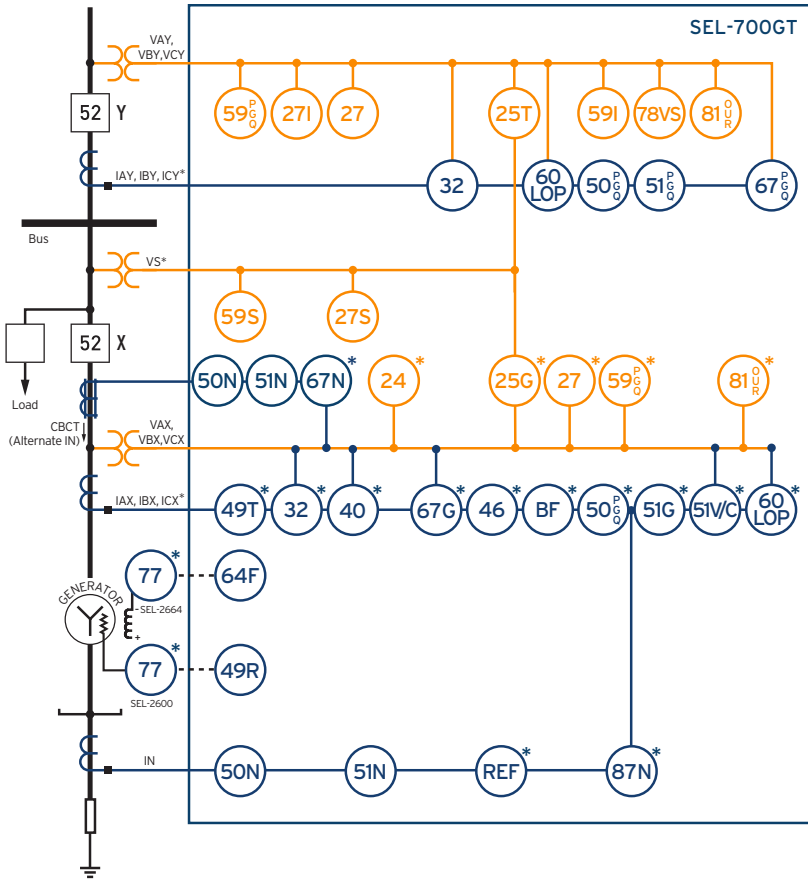

## ANSI Numbers/Acronyms and Functions

21C/51VC	Compensator Distance, Voltage Restrained/Controlled Time-Overcurrent
24	Volts/Hertz
25G	Generator Synchronism Check
25T	Tie Synchronism Check
27	Undervoltage
27I	Inverse-Time Undervoltage
27S	Synchronism Undervoltage
32	Directional Power
40	Loss-of-Field
46	Current Unbalance
49R	Thermal Overload (Resistance Temperature Detector [RTD])
49T	Thermal Model
50N	Neutral Overcurrent
50 (P,G,Q)	Overcurrent (Phase, Ground, Neg. Seq.)
51 (P,G,Q)	Time-Overcurrent (Phase, Ground, Neg. Seq.)
51C	Voltage-Controlled Phase Time-Overcurrent
51N	Neutral Time Overcurrent
51V	Voltage-Restrained Phase Time-Overcurrent
59I	Inverse Time Overvoltage
59N (64G1)	Neutral Overvoltage
59S	Synchronism Overvoltage
59 (P,G,Q)	Overvoltage (Phase, Ground, Neg. Seq.)
60	Loss-of-Potential
64F	Field Ground
64G	100% Stator Ground
67 (P,G,Q)	Directional Overcurrent (Phase, Ground, Neg. Seq.)
67N	Directional Neutral Overcurrent
77	Telemetering Device
78	Out-of-Step
78VS	Vector Shift
81 (O,U,R)	Frequency (Over, Under, Rate)
87	Three-Phase Current Differential
87N	Neutral Current Differential
REF	Restricted Earth Fault

## Additional Functions

52PB	Pushbutton Trip/Close
85 RIO	SEL MIRRORED BITS® Communications
BF	Breaker Failure
BRM	Breaker Wear Monitor
DFR	Event Reports
ENV	SEL-2600
HMI	Operator Interface
LDP	Load Data Profiling
LGC	SELogic® Control Equations
MET	High-Accuracy Metering
PMU	Synchrophasors
RTU	Remote Terminal Unit
SER	Sequential Events Recorder
WEB	Web Server

\*Optional Feature    †Copper or Fiber-Optic

# Key Features

## Comprehensive Generator Protection

Connect the SEL-700G Generator Protection Relay across small, medium, or large generators for complete primary and backup protection. Adding the neutral voltage connection provides 100 percent stator ground protection, based on fundamental-frequency and third-harmonic neutral voltage measurements. Connecting the neutral current input provides protection for solidly grounded or resistance-grounded generators.

## Automatic Synchronizer

Replace external generator control and synchronizer relays with the built-in automatic synchronizer function. The SEL-700G automatically synchronizes the frequency, voltage, and phase control of the generator with the power system. Generator start reports and the PC-based synchroscope allow you to monitor the generator synchronization. The built-in automatic synchronizer function is available on select SEL-700G models.

## Islanding Protection

Detect islanding conditions using the vector shift function. The vector shift function provides another element of protection for distributed generators connected to the utility network. It operates within three cycles—fast enough to prevent out-of-synchronization reclosing with the network feeders to avoid generator damage.

## Easy Communications

Choose from single or dual copper or fiber-optic Ethernet ports, serial communications, and several protocols, including MIRRORRED BITS communications, IEC 61850 Edition 2, EtherNet/IP, the IEEE 1588 Precision Time Protocol (PTP) (software-based), IEC 60870-5-103, and the Parallel Redundancy Protocol (PRP). Multiple Modbus TCP or Modbus serial sessions are available for custom configuration of your application. You can also use DNP3 serial or DNP3 LAN/WAN protocols. In addition, the IEC 61850 test mode enables in-service testing, which reduces commissioning time.



### Breaker Wear Monitoring

Record accumulated breaker contact wear with the breaker monitor function, which uses the breaker manufacturer's specifications for defining operation limits. The internal monitor tracks the total number of close/open operations and integrates the interrupted current per phase. You can set an alarm to alert operators when measured and accumulated quantities approach maintenance thresholds. This information facilitates proactive breaker maintenance and replacement without underutilizing resources.

### Current Differential Protection

Apply sensitive percentage-restrained current differential elements and an unrestrained element, along with synchronism-check and volts-per-hertz elements, across the entire unit to protect both the generator and the step-up transformer. Optional current differential elements detect stator faults using a secure, sensitive current differential function. Power transformer and CT connection compensation allows you to include the unit step-up transformer in the generator differential zone.

### Synchrophasor Data

Apply SEL synchrophasors (IEEE C37.118-2005) to turn state estimation into state measurement and to provide early warning of potential system instability. The SEL-700G phasor measurement accuracy meets the IEEE C37.118-2005 Level 1 requirement. Users can also visualize and synchronize system parameters on the device using the available color touchscreen display.

### Reliable, Rugged Hardware

The SEL-700G operates in extreme conditions, with an operating temperature range of  $-40^{\circ}$  to  $+85^{\circ}\text{C}$  ( $-40^{\circ}$  to  $+185^{\circ}\text{F}$ ). It withstands vibration, electrical surges, fast transients, and extreme temperatures, meeting stringent industry standards. A conformal-coating option for the printed circuit boards provides an additional barrier against airborne contaminants, such as hydrogen sulfide, chlorine, salt, and moisture. In addition, the SEL-700G is ATEX-certified and Underwriters Laboratories (UL) Class I, Division 2-certified for use in hazardous and potentially explosive environments.



# Product Overview

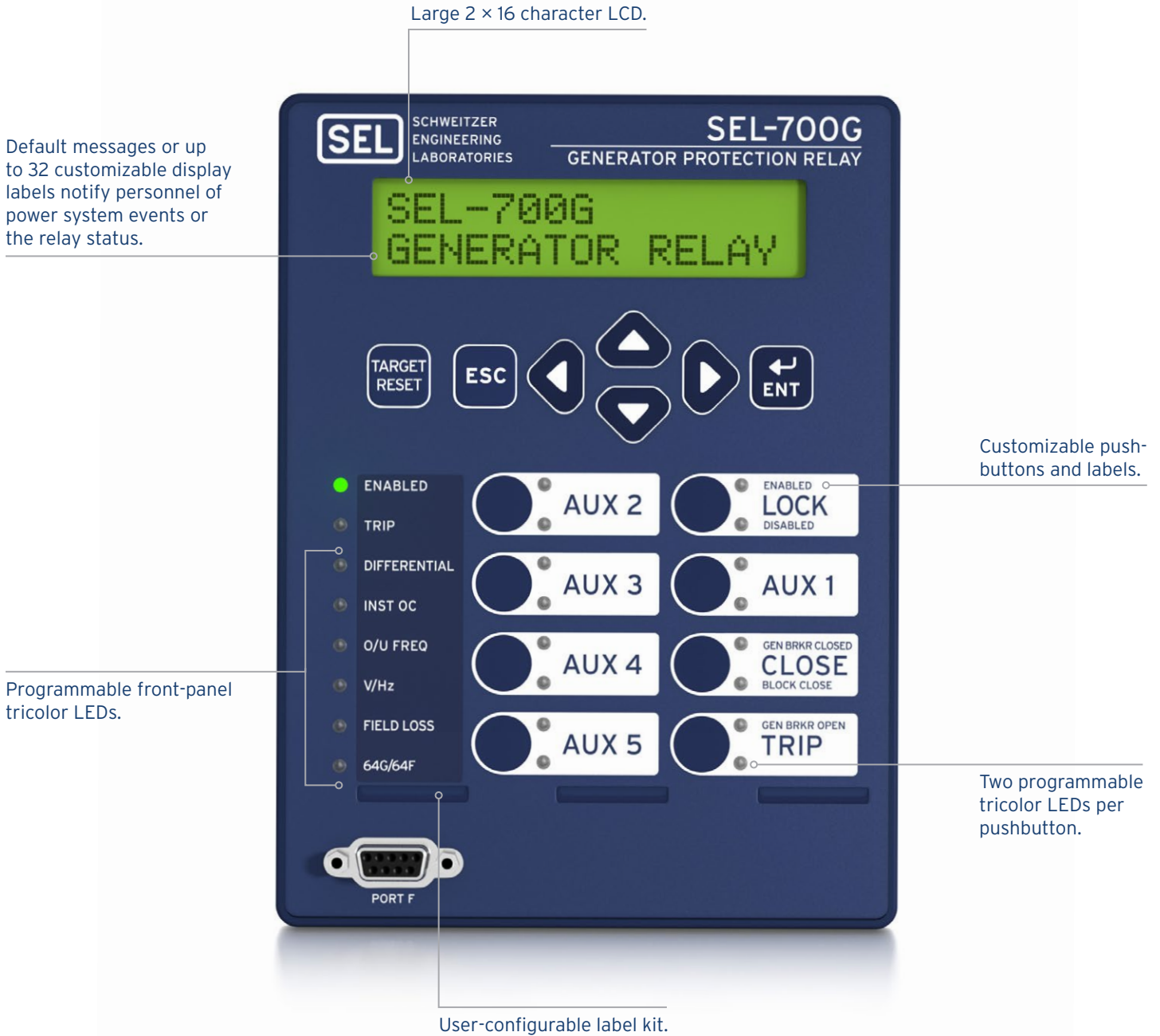

Power supply options include 24–48 Vdc or 110–250 Vdc/110–240 Vac.

A wide variety of communications protocols and media provide flexibility to communicate with other devices and control systems.

Accelerate firmware downloads via the Ethernet port.

Positions for optional expansion cards.

Fiber-optic serial port.

MIRRORED BITS communications provides fast and reliable relay-to-relay communication.

Optional RTD inputs.

Voltage and current inputs.

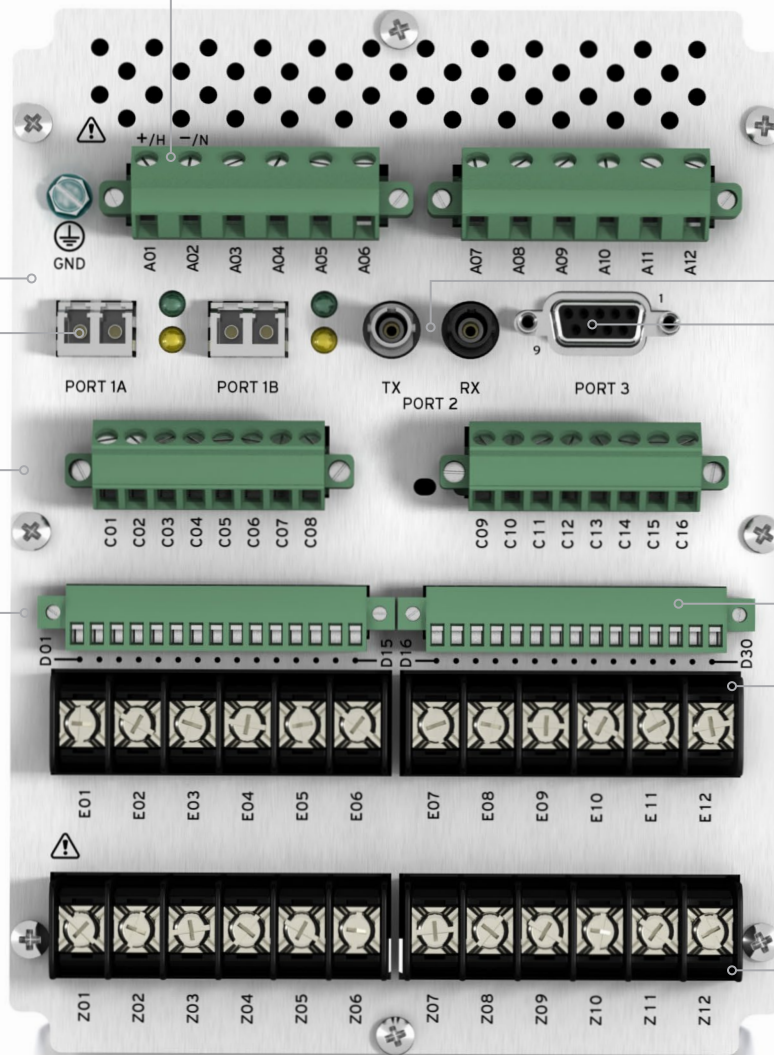

# Touchscreen Overview

The 5-inch diagonal color display with a resolution of 800 × 480 offers direct navigation via a capacitive touchscreen.

A full onscreen keyboard facilitates easy adjustment of settings.

Folders and applications provide quick access to bay screens, metering and monitoring data, reports, settings, and more.

The home pushbutton allows users to easily return to the default home screen.

The front panel is available in English or Spanish.

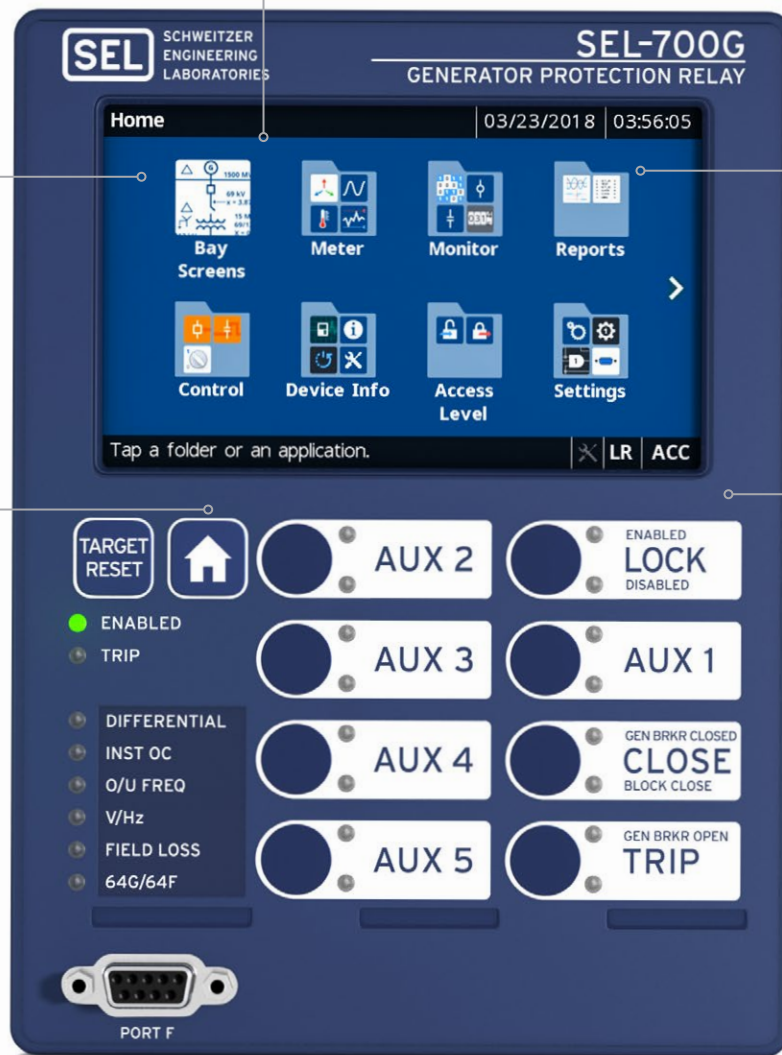

# Touchscreen Display Features and Functions

The SEL-700G 5-inch, 800 × 480 color touchscreen display provides a one-line diagram mimic display for bay control and monitoring. You can view metered quantities, phasor diagrams, relay settings, event summaries, target statuses, and SER data.

## Bay Screens and Bay Control

Select from predefined bay screens, or configure as many as five custom bay screens using the ACSELERATOR® Bay Screen Builder SEL-5036 Software and ACSELERATOR QuickSet® SEL-5030 Software. With the bay screen, you can control as many as two breakers, eight two-position disconnects, and two three-position disconnects and can view analog and digital data in a contextual display.

To control a breaker, simply tap the Bay Screens application on the home screen and then the breaker you want to control.

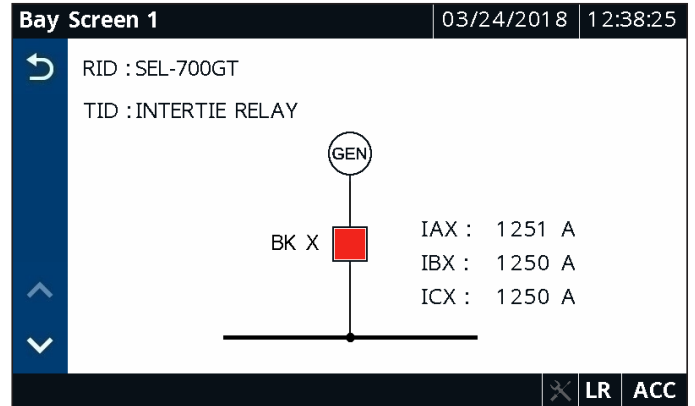

Next, enter your Level 2 password and tap Submit. The onscreen keyboard allows you to quickly and easily enter passwords, search for Relay Word bits, and enter settings whenever necessary.

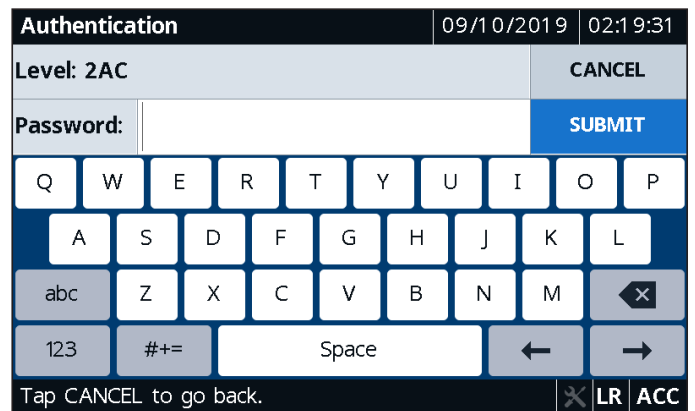

Finally, tap Trip or Close to control the breaker. When asked to confirm the action before the operation is completed, choose Yes or No.

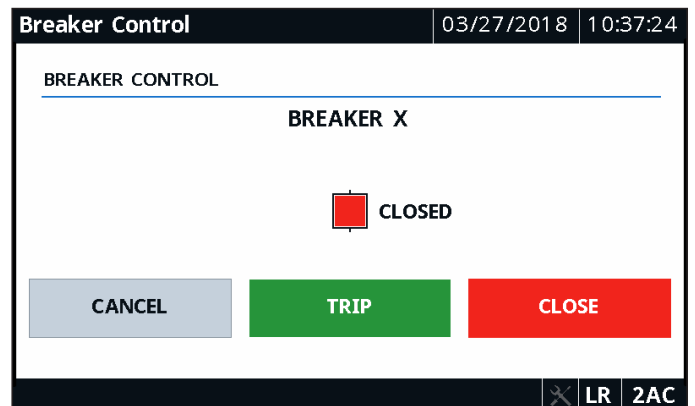

### Meter Fundamentals

View the real, reactive, and apparent power of each phase in your system, and monitor the power factor information to determine if the phase current leads or lags the phase voltage.

Fundamental Metering		03/27/2018	10:43:10
	A	B	C
PX (kW)	7502	7549	7519
QX (kVAR)	4089	4069	4081
SX (kVA)	8542	8575	8558
PFX	0.88 LAG	0.88 LAG	0.88 LAG

### Meter Phasors

View a graphical and textual representation of the real-time voltages and currents in a power system during balanced and unbalanced conditions. By analyzing the phasors, you can determine power system conditions.

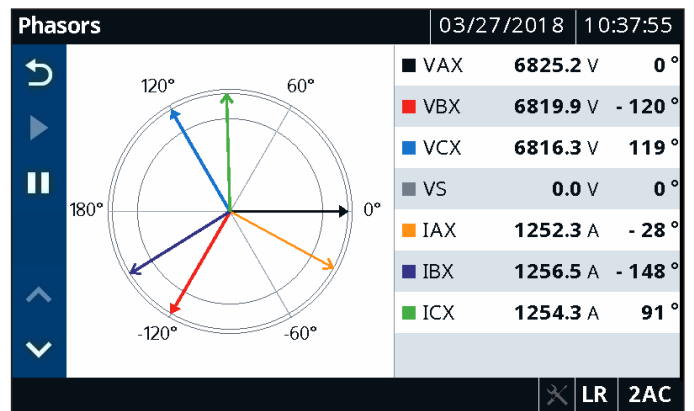

### Meter Energy

Display the real, reactive, and apparent energy metering quantities imported and exported by your system. You can reset the energy values via the display and record the time and date of reset. Whether your system is a net energy producer or consumer, metered quantities accurately account for the power system energy flow.

Energy Metering		03/27/2018	10:48:02
Positive MWHX (MWh)	1.688	Negative MWHX (MWh)	0.000
Positive MVARHX (MVARh)	0.898	Negative MVARHX (MVARh)	0.000
		LAST RESET	
		03/27/2018 10:46:11	

### Visualize and Control Synchronization

Use the Synchroscope application in the Monitor folder to view a graphical representation of the phasor difference between the bus and the generator or the tie. You can also use the Autosynchronization application in the Control folder to initiate autosynchronization. With the touch of a finger, you can automatically synchronize the frequency, voltage, and phase angle of the generator and connect to the power system. This eliminates the need for expensive external synchronizing equipment.

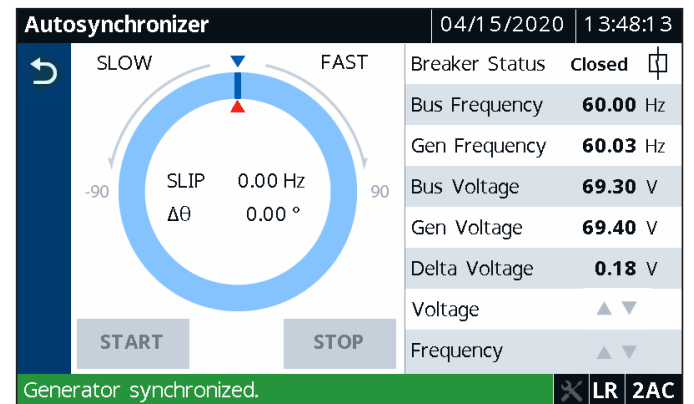

# Applications

Eliminate the complexity and cost of standalone synchronizer packages. The SEL-700G provides a comprehensive protection and synchronization solution for synchronous generators. Integrating the synchronization capability into the generator protection relay provides the most cost-effective and reliable solution.

The optional SEL-2664 Field Ground Module accurately detects field ground faults whether the generator is operating, stopped, or de-energized.

## Unit Protection

Apply sensitive percentage-restrained current differential elements and an unrestrained element, along with synchronism-check and volts-per-hertz elements, across the entire unit to protect both the generator and the step-up transformer. Harmonic blocking elements protect the unit transformer bushing and end windings while maintaining security for inrush and through-fault conditions.

## Stator/Field Ground Protection

Adding the neutral voltage connection provides 100 percent stator ground protection for most generators, based on fundamental-frequency and third-harmonic neutral-voltage measurements. Connecting the neutral current input provides protection for solidly grounded or resistance-grounded generators. State-of-the-art voltage injection provided by the SEL-2664 module allows you to monitor field ground insulation resistance. You can protect generators from damage by responding to low field ground insulation resistance warnings.

## Automatic Generator Control

SEL's generation control system regulates generator power outputs and manages utility interties to maximize system stability, minimize electrical disturbances, and mitigate load-shedding requirements. The SEL-700G in combination with the SEL POWERMAX® Power Management and Control System can balance generation loading, control tie line power flow, and maintain bus voltage.

The automatic MVAR and voltage control system maintains MVAR flows on interties and system bus voltages by controlling load tap changers, generator field and large synchronous motor exciters, synchronous and static condensers, and capacitor banks.

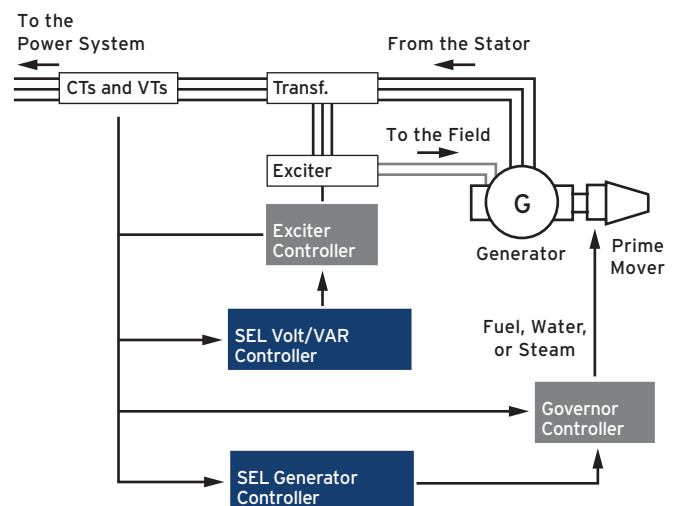
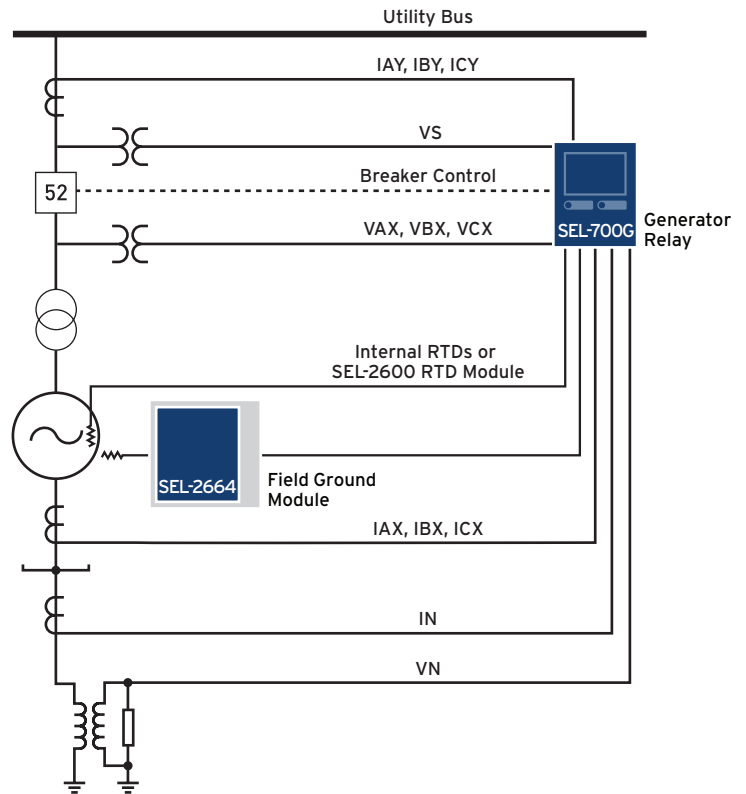

## Metering and Reporting

View generator automatic synchronizer, SER, and 180-cycle oscillographic event reports in COMTRADE and CEV formats to analyze generator startup, shutdown, or system faults. The SEL-700G measures electrical, thermal, and generator run-time quantities and allows you to retrieve COMTRADE files via the Ethernet File Transfer Protocol (FTP) or IEC 61850 MMS.

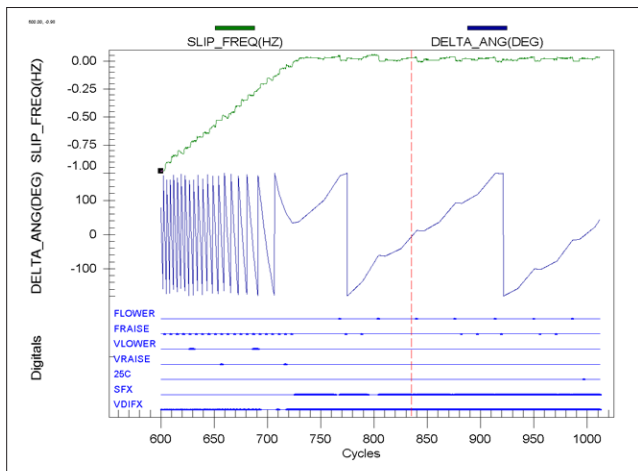

## Autosynchronization

Use the additional, built-in automatic synchronizer function to automatically synchronize the frequency, voltage, and phase angle of the generator and connect to the power system. This eliminates the need for expensive external synchronizing equipment. In addition, you can use a digital app with the available touchscreen display to visualize and synchronize system parameters.

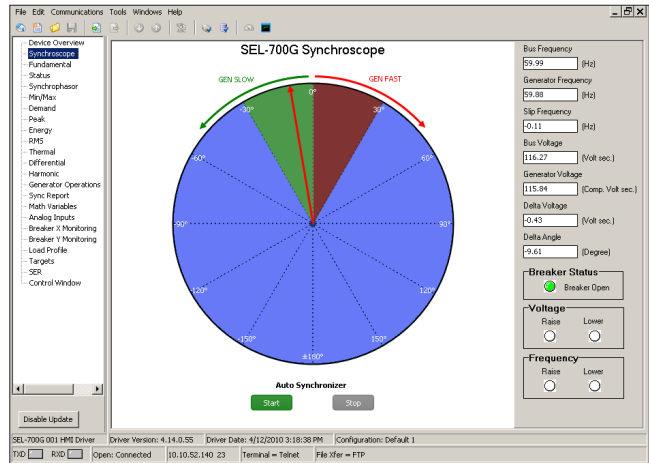

## RTD-Based Thermal Protection

Acquire thermal data for alarm, monitoring, and trip functions in the SEL-700G with a 10 RTD input card or an external 12 RTD SEL-2600 RTD Module.

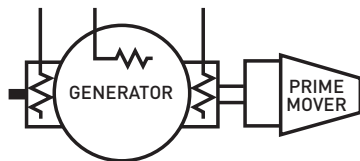

## Synchrophasor Measurement

Combine the SEL-700G with an SEL IRIG-B time source to measure the system angle in real time with a timing accuracy of  $\pm 10 \mu\text{s}$ . You can measure instantaneous voltage and current phase angles in real time to improve system operation with synchrophasor information.

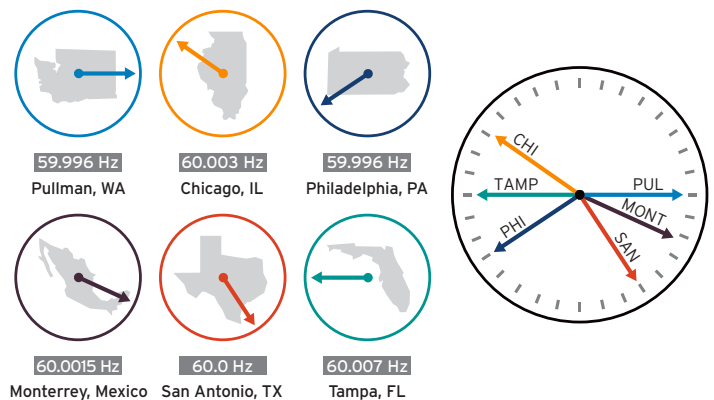

View of system angle at multiple locations.

# Easy to Set and Use

## Use QuickSet Software to Set, Monitor, and Control the SEL-700G

With QuickSet, you can:

- Communicate with the SEL-700G through any ASCII terminal, or use the QuickSet graphical user interface.
- Develop settings offline with a menu-driven interface and completely documented help screens. You can speed up installation by copying existing settings files and modifying application-specific items.
- Simplify the settings procedure with rules-based architecture to automatically check interrelated settings. Out-of-range or conflicting settings are highlighted for correction.
- Use the acSELEATOR HMI synchroscope to view the real-time synchronization process.
- Set an HMI pushbutton to initiate the generator synchronization process.

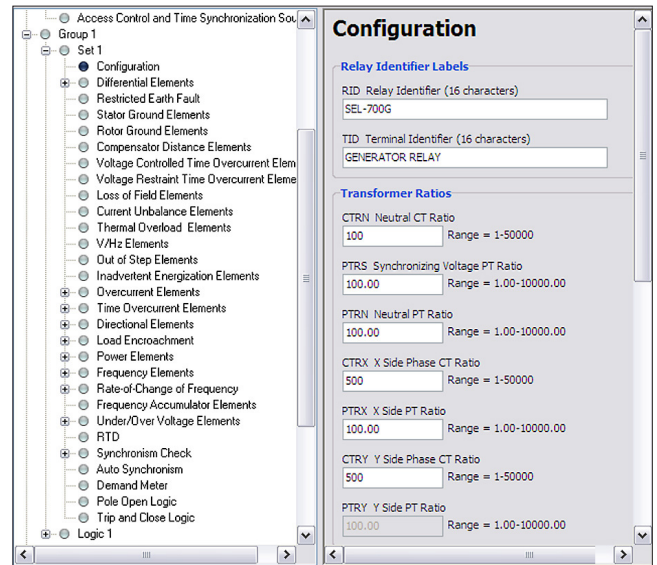

## Integrated Web Server

Access basic SEL-700G information on a standard Ethernet network with the built-in web server. View the relay status, SER data, metering information, and settings with easy access within a local network. For increased security, web server access requires a relay password and the information is limited to a read-only view. You can also upgrade the relay firmware through the web server.

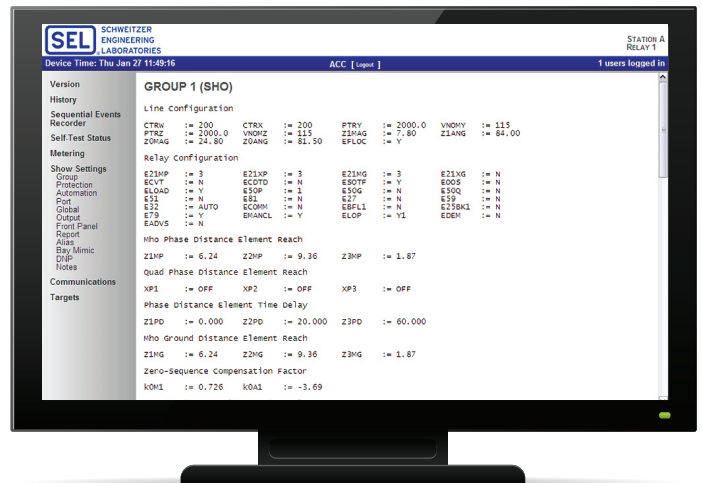

## Use SEL-5601-2 SYNCHROWAVE® Event Software to Retrieve and Display Event Reports Recorded by the SEL-700G

With SYNCHROWAVE software, you can:

- Display event report oscillograms. You can view each report as a plot of magnitude versus time and select analog and digital points to build a custom display.
- Display phase and symmetrical component phasors. Displaying the phasor view of electrical data helps you better understand asymmetrical, three-phase faults. You can build a custom plot using per-phase and symmetrical component sequence currents and voltages.
- Retrieve event reports using serial or Ethernet communications links.



## Retrofit Replacement Kits

Easily replace existing generator protection with the SEL-700G and the applicable mounting kit. These kits provide everything needed to replace many existing generator relays with the SEL-700G.

No cutting or drilling is required when you use the optional mounting kits. Replacement of existing protection is quick and easy.



## SEL-700G Options

Current and Voltage Input Cards Model	Model	Optional Communications and I/O Cards
3 currents, 1 neutral current, 3 voltages (Slot Z)	SEL-700G0	Serial communications card (EIA-232/-485)
3 currents, 1 neutral current, 3 voltages (Slot Z) and 1 voltage (battery or synchronism check) (Slot E)	SEL-700G0+	3 digital inputs (DI), 4 digital outputs (DO), 1 4–20 mA analog output (AO)
3 currents, 1 neutral current, 3 voltages (Slot Z) and 3 currents (Slot E)	SEL-700G1	4 DI, 4 DO
3 currents, 1 neutral current, 3 voltages (Slot Z) and 3 currents, 1 voltage (battery or synchronism check) (Slot E)	SEL-700G1+	8 DO
1 neutral current (Slot Z) and 3 currents, 1 voltage (synchronism check), 3 voltages (Slot E)	SEL-700GT	8 DI
3 currents, 1 neutral current, 3 voltages (Slot Z) and 3 currents, 1 voltage (synchronism check), 3 voltages (Slot E)	SEL-700GT+	14 DI
3 currents (Slot Z) and 3 voltages (Slot E)	SEL-700GW	4 DI, 3 DO (2 Form C, 1 Form B)
		4 analog inputs (AI)/4 AO
		10 RTD inputs

# SEL-700G Specifications

## General

<b>Displays</b>	2-line × 16-character LCD 5-inch color touchscreen display, 800 × 480 pixels
<b>AC Current Inputs</b>	5 A or 1 A phase and 5 A or 1 A neutral
<b>AC Voltage Inputs</b>	300 Vac continuous, 600 Vac for 10 seconds
<b>Output Contacts</b>	The relay supports Form A, B, and C outputs.
<b>Optoisolated Control Inputs</b>	DC/AC control signals: 250, 220, 125, 110, 48, or 24 V As many as 26 inputs are allowed in ambient temperatures of 85°C (185°F) or less. As many as 34 inputs are allowed in ambient temperatures of 75°C (167°F) or less. As many as 44 inputs are allowed in ambient temperatures of 65°C (149°F) or less.
<b>Frequency and Phase Rotation</b>	System frequency: 50, 60 Hz Phase rotation: ABC, ACB Frequency tracking: 15–70 Hz (requires ac voltage inputs)
<b>Autosynchronizing</b>	Frequency matching: ±0.1% plus ±4.2 ms at 60 Hz Voltage matching: VAY, VBY, VCY, VABY, VBCY, BCAY, or angle from VAY or VABY
<b>Communications Protocols</b>	SEL (Fast Meter, Fast Operate, and Fast SER), EtherNet/IP, Modbus TCP/IP, Modbus RTU, DNP3, FTP, IRIG-B, Telnet, the Simple Network Time Protocol (SNTP), IEC 61850 Edition 2, IEC 60870-5-103, software-based IEEE 1588 PTP, PRP for dual-Ethernet models, MIRRORRED BITS communications, and IEEE C37.118-2005 (synchrophasors).
<b>Language Support</b>	English and Spanish
<b>Power Supply</b>	<b>110–250 Vdc or 110–240 Vac</b> Input voltage range: 85–275 Vdc or 85–264 Vac <b>24–48 Vdc</b> Input voltage range: 19.2–60 Vdc
<b>Operating Temperature</b>	–40° to +85°C (–40° to +185°F) Note: Front-panel display contrast is impaired for temperatures below –20°C (–4°F) and above +70°C (+158°F).
<b>Certifications</b>	To view certifications for the SEL-700G, please visit <a href="http://selinc.com/company/certifications">selinc.com/company/certifications</a> .

**SEL** SCHWEITZER ENGINEERING LABORATORIES

Making Electric Power Safer, More Reliable, and More Economical  
+1.509.332.1890 | info@selinc.com | selinc.com

© 2020 by Schweitzer Engineering Laboratories, Inc.  
PF00211 • 20200521

