

SEL-700BT

Motor Bus Transfer Relay



Comprehensive bus transfer protection for critical process environments

- Transfers critical loads from a primary source to an auxiliary feeder during faults in the primary feeder line.
- Allows automatic and manual motor bus transfers to keep processes running without requiring a cold start.
- Provides primary and backup motor bus protection with current, voltage, frequency, distance, loss-of-potential, and out-of-step elements.
- Allows for the quick configuration, monitoring, and control of your system via the color touchscreen display.



Functional Overview

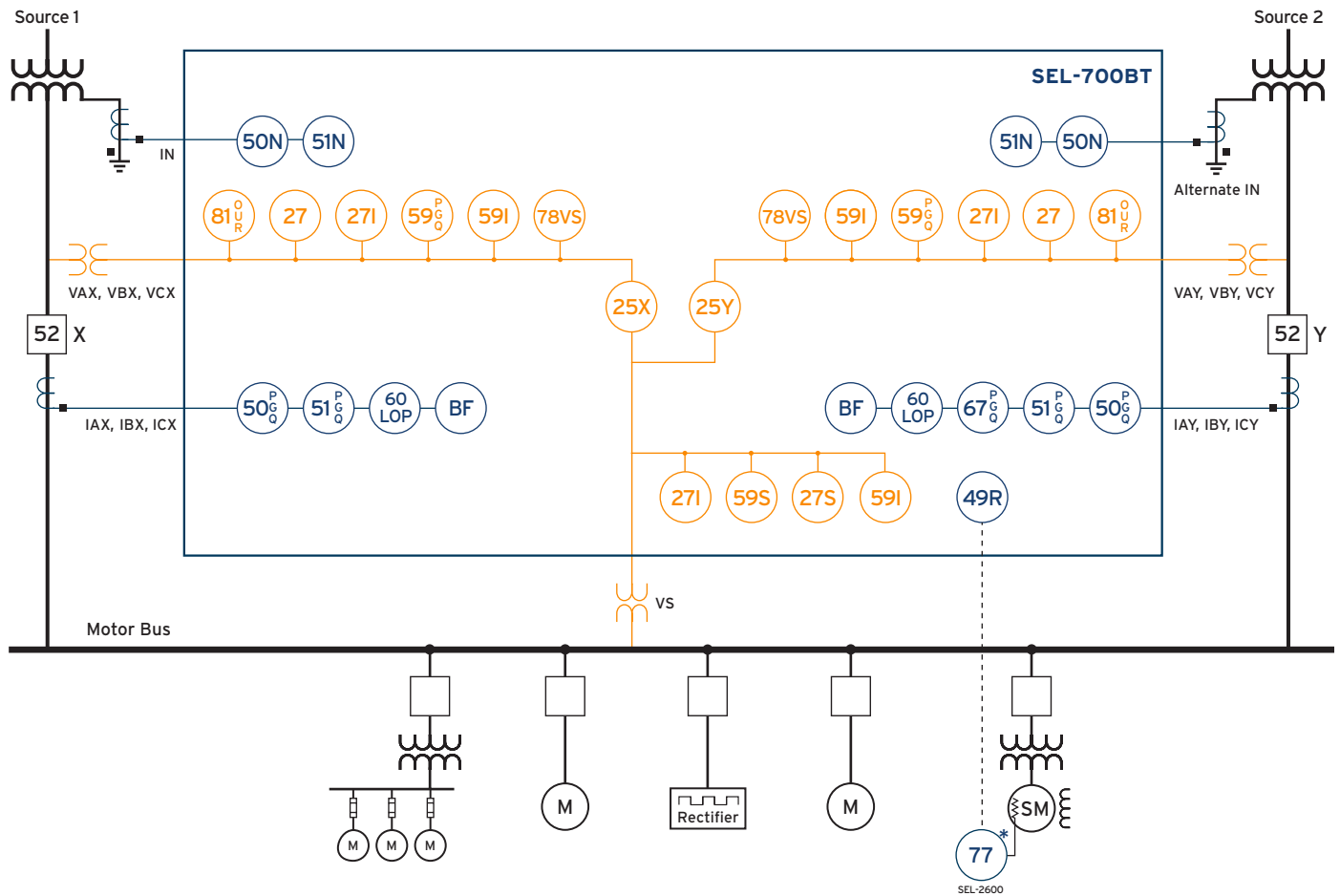

ANSI Functions

25 (X,Y)	Synchronism Check
27	Undervoltage
27I	Inverse-Time Undervoltage
27S	Synchronism Undervoltage
49R	Thermal Overload
50N	Neutral Overcurrent
50 (P,G,Q)	Overcurrent (Phase, Ground, Negative Sequence)
51N	Neutral Time Overcurrent
51 (P,G,Q)	Time Overcurrent (Phase, Ground, Negative Sequence)
59I	Inverse-Time Overvoltage
59S	Synchronism Overvoltage
59 (P,G,Q)	Overvoltage (Phase, Ground, Negative Sequence)
60LOP	Loss of Potential
67 (P,G,Q)	Directional Overcurrent (Phase, Ground, Negative Sequence)
77	Field Device*

78VS	Vector Shift
81 (O,U,R)	Over-/Underfrequency, Rate-of-Change of Frequency

Additional Functions

85 RIO	SEL MIRRORED BITS® Communications
BF	Breaker Failure
BRM	Breaker Wear Monitor
DFR	Event Reports
HMI	Operator Interface
LDP	Load Data Profiling
LGC	SELogic® Control Equations
MET	High-Accuracy Metering
SER	Sequential Events Recorder
WEB	Web Server

*Optional feature

Key Features

Motor Bus Transfer Protection

Because industrial facilities with critical processes require a reliable supply of electric power, they typically have two incoming sources. To ensure process continuity during a fault to the primary feeder, the SEL-700BT Motor Bus Transfer Relay quickly and safely transfers loads to an auxiliary feeder via one of four transfer methods: fast, in-phase, residual, or fixed-time. This instantaneous transfer of load keeps processes running without requiring a cold start, helps avoid costly shutdowns, provides personnel safety, and helps avoid environmental damage. Manual load transfer is also possible locally or remotely via communications.

Comprehensive System Protection

Protect equipment using phase, negative-sequence, residual-ground, and neutral-ground overcurrent elements with directional control. You can also apply phase, negative-sequence, residual-ground, and neutral-ground time-overcurrent elements. The SEL-700BT includes many advanced protection features that ensure secure and reliable operation, such as synchronism check and rate-of-change-of-frequency (ROCOF) controls.

Easy Communications

Choose from single or dual copper or fiber-optic Ethernet ports, serial communications, and several protocols, including MIRRORING BITS communications, IEC 61850 Edition 2, EtherNet/IP, the software-based IEEE 1588 Precision Time Protocol (PTP), IEC 60870-5-103, and the Parallel Redundancy Protocol (PRP). Multiple Modbus

TCP or Modbus serial sessions are available for custom configuration of your application. You can also use DNP3 serial or DNP3 LAN/WAN protocols. In addition, the IEC 61850 test mode enables in-service testing, which reduces commissioning time.

Breaker Wear Monitoring

Record accumulated breaker contact wear with the breaker monitor function, which uses the breaker manufacturer's specifications for defining operation limits. The internal monitor tracks the total number of close/open operations and integrates the interrupted current per phase. You can set an alarm to alert operators when measured and accumulated quantities approach maintenance thresholds. This information facilitates proactive breaker maintenance and replacement.

Reliable, Rugged Hardware

The SEL-700BT operates in extreme conditions, with an operating temperature range of -40° to $+85^{\circ}\text{C}$ (-40° to $+185^{\circ}\text{F}$). It withstands vibration, electrical surges, fast transients, and extreme temperatures, meeting stringent industry standards. A conformal-coating option for the printed circuit boards provides an additional barrier against airborne contaminants, such as hydrogen sulfide, chlorine, salt, and moisture. In addition, the SEL-700BT is ATEX-certified and Underwriters Laboratories (UL) Class I, Division 2-certified for use in hazardous and potentially explosive environments.



Product Overview

The 5-inch, 800 × 480 display offers direct navigation via a capacitive touchscreen.

Folders and applications provide quick access to bay screens, metering and monitoring data, reports, settings, and more.

Programmable front-panel LEDs with user-configurable labels alert operators to faulted phases, the relay's status, and element operation.

Programmable operator pushbuttons with user-configurable labels allow front-panel customization.

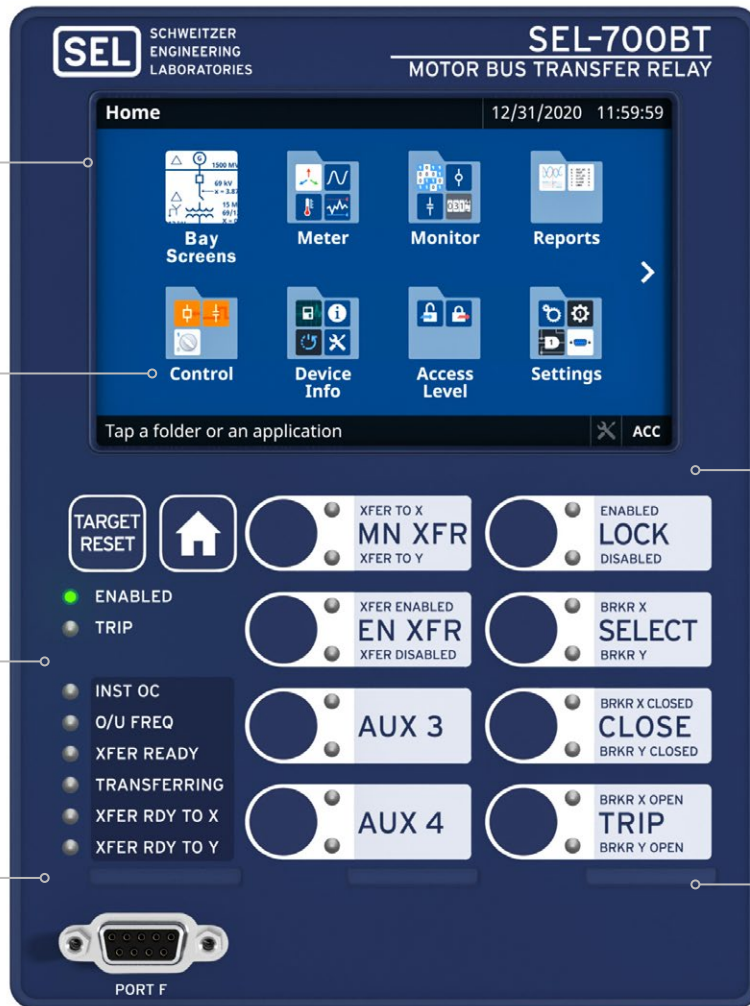

Power supply options include 24–48 Vdc or 110–250 Vdc/110–240 Vac.

A wide variety of communications protocols and media provide flexibility to communicate with other devices and control systems.

Positions for optional expansion cards.

Voltage and current inputs.

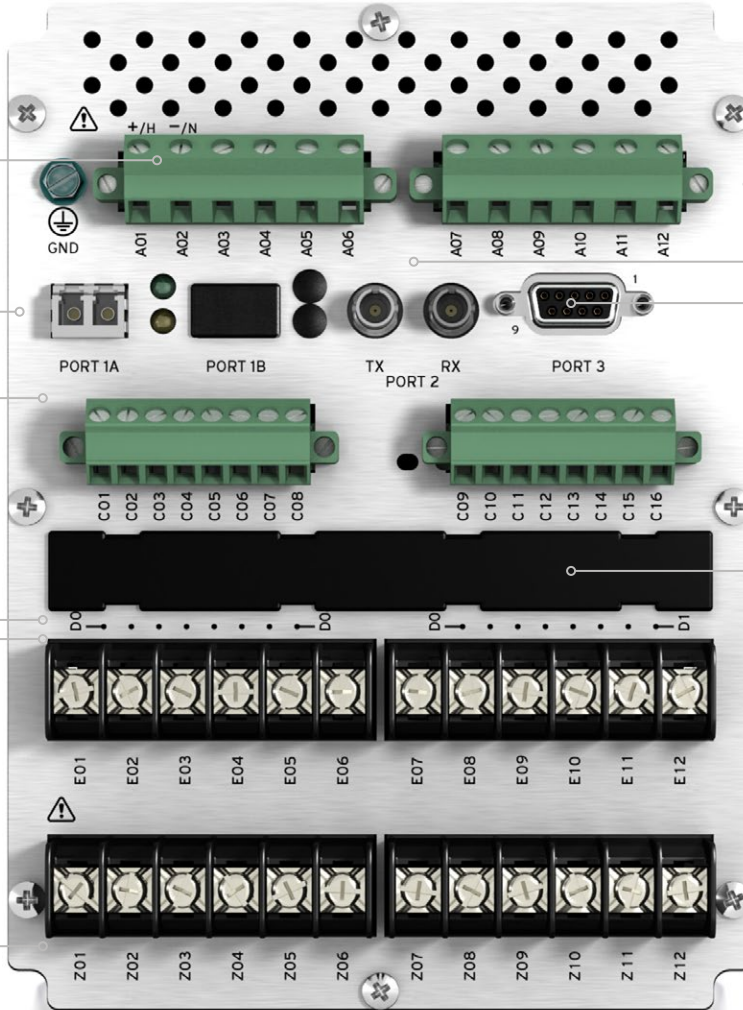

An integrated web server enables direct relay access for metering and monitoring data without the need for external PC software.

Fiber-optic serial port.

MIRRORED BITS communications provides fast and reliable relay-to-relay communication.

Optional resistance temperature detector (RTD) inputs.

Touchscreen Display Features and Functions

The SEL-700BT relay comes standard with a 5-inch, 800 × 480 color touchscreen display, which provides a one-line diagram mimic display for bay control and monitoring. You can view metered quantities, phasor diagrams, relay settings, event summaries, target statuses, and SER data.

Bay Screens and Bay Control

Select from predefined bay screens for various configurations, including main-main and main-tie-main. You can also configure as many as five custom bay screens using the ACSELERATOR® Bay Screen Builder SEL-5036 Software and ACSELERATOR QuickSet® SEL-5030 Software.

With the bay screen, you can control multiple breakers and disconnects, initiate source transfers, and control the bus transfer scheme.

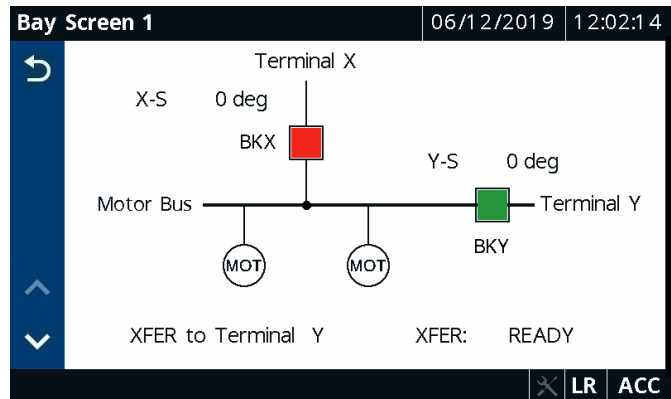
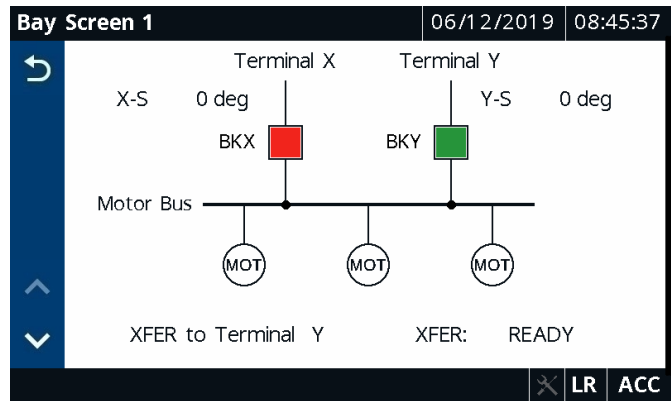

Breaker Control

To control a breaker, simply tap the bay screens application on the home screen and then the breaker you want to control. When asked to confirm the action, choose Yes to complete the action.

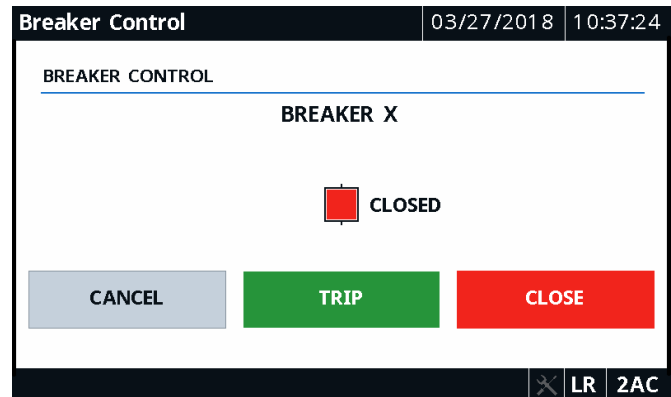

Meter Fundamentals

View the real, reactive, and apparent power of each phase in your system, and monitor the power factor information to determine if the phase current leads or lags the phase voltage.

Fundamental Metering				03/27/2018	10:43:10
	A	B	C		
PX (kW)	7502	7549	7519		
QX (kVAR)	4089	4069	4081		
SX (kVA)	8542	8575	8558		
PFX	0.88 LAG	0.88 LAG	0.88 LAG		

Meter Phasors

View a graphical and textual representation of the real-time voltages and currents in a power system during balanced and unbalanced conditions. By analyzing the phasors, you can determine power system conditions.

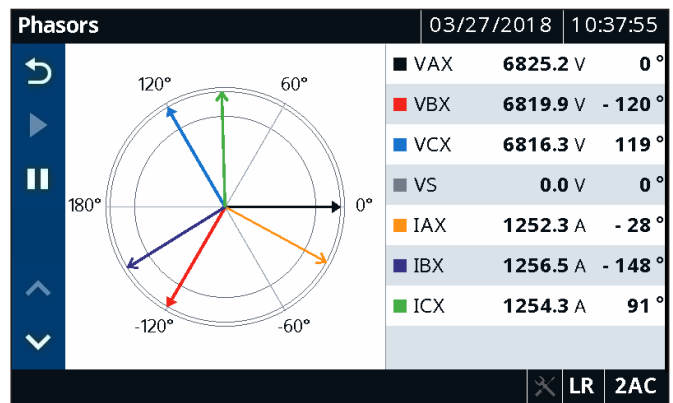

Meter Energy

Display the real, reactive, and apparent energy metering quantities imported and exported by your system. You can reset the energy values via the display and record the time and date of reset. Whether your system is a net energy producer or consumer, metered quantities accurately account for the power system energy flow.

Energy Metering		03/27/2018	10:48:02
Positive MWHX (MWh)	1.688	Negative MWHX (MWh)	0.000
Positive MVARHX (MVARh)	0.898	Negative MVARHX (MVARh)	0.000
		LAST RESET	
		03/27/2018 10:46:11	

Full On-Screen Keyboard

Quickly and easily enter passwords, search for Relay Word bits, and enter or edit settings via the full on-screen keyboard.

Authentication		09/10/2019	02:19:31						
Level: 2AC	CANCEL								
Password:	SUBMIT								
Q	W	E	R	T	Y	U	I	O	P
A	S	D	F	G	H	J	K	L	
abc	Z	X	C	V	B	N	M	X	
123	#+=	Space		←		→			
Tap CANCEL to go back.				LR ACC					

Applications

Motor Bus Transfer Solution

The SEL-700BT has built-in logic for motor bus transfer, which allows for the instantaneous transfer of load to an auxiliary feeder from the primary feeder during faults to the primary feeder. Manual load transfer is also possible locally or remotely via communications. The four automatic bus transfer methods available include:

- Fast, in which the transfer occurs shortly after the first breaker opens and before the phase of the residual voltage deviates from the system.

- In-phase, which occurs when the phase of the system voltage and the residual voltage align.
- Residual, in which the relay waits for the residual voltage to fall below a certain threshold before transferring the bus.
- Fixed-time, which is configurable via SELogic control equations.

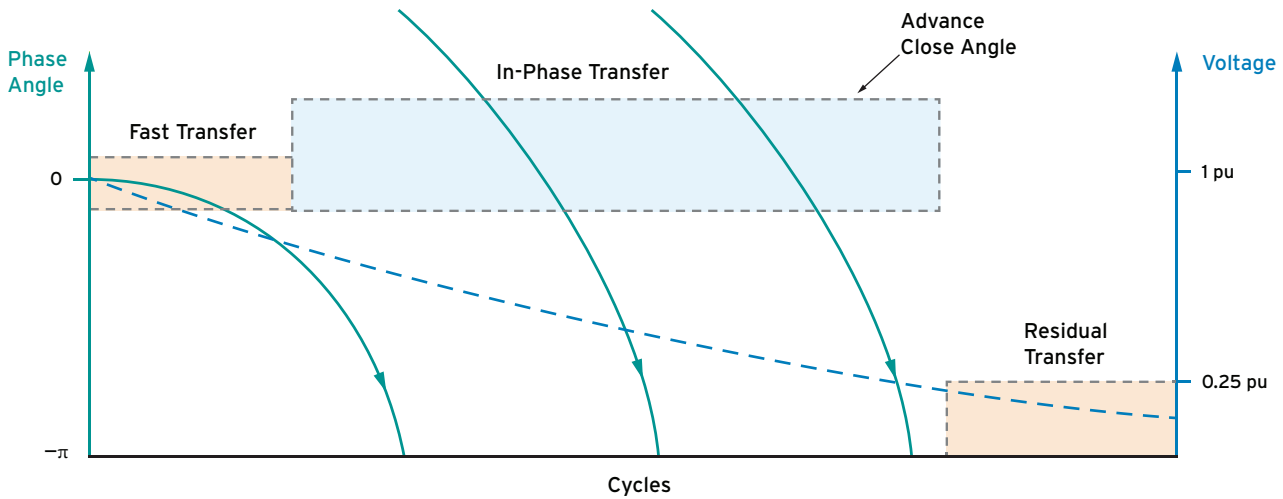

Main-Main Configuration

A single SEL-700BT can protect and control a critical main-main load bus by selecting from two sources automatically.

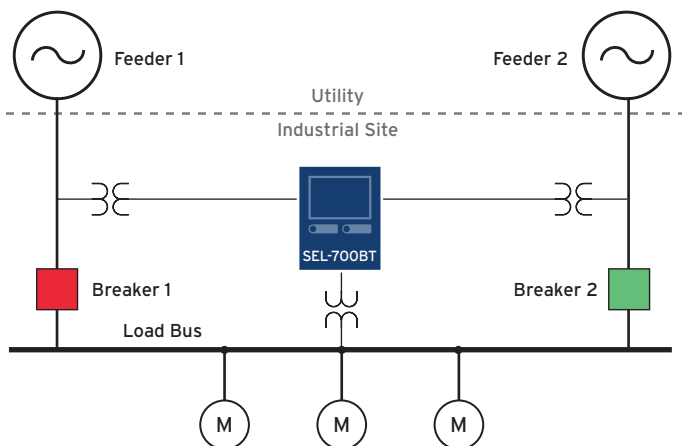

Main-Tie-Main Configuration

Two SEL-700BT relays (one on each side of the inertia) are used to transfer the load bus between sources in a main-tie-main configuration. This allows the system to retain load diversity during normal operation and enables advanced transfer functions.

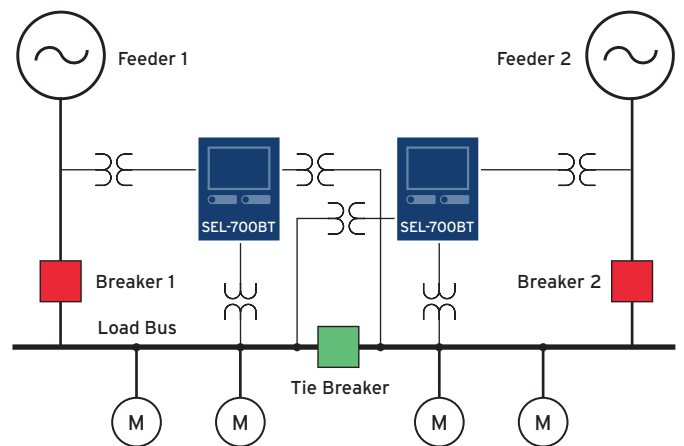

Complete Overcurrent Protection

Apply instantaneous and directional instantaneous overcurrent and time-overcurrent protection with as many as two sets of three-phase CTs and one neutral CT input. Phase overcurrent protection is provided for both three-phase inputs.

RTD-Based Thermal Protection

Acquire thermal data for alarm, monitoring, and trip functions in the SEL-700BT with a 10 RTD input card or an external 12 RTD SEL-2600 RTD Module.

Synchronism Check

The built-in synchronism-check function provides supervision on both the X side and the Y side for the acceptable voltage window and maximum percentage difference, maximum and minimum allowable slip frequency, target closing angle, and breaker closing delay. The tie synchronism-check function provides the closing window for the bus-tie breaker when connecting to a utility system.



Use SEL-5601-2 SYNCHROWAVE® Event Software to Retrieve and Display Event Reports Recorded by the SEL-700BT

With SYNCHROWAVE Event, you can:

- Display event report oscillograms. You can view each report as a plot of magnitude versus time and select analog and digital points to build a custom display.
- Display phase and symmetrical component phasors. Displaying the phasor view of electrical data helps you better understand asymmetrical, three-phase faults. You can build a custom plot using per-phase and symmetrical component sequence currents and voltages.
- Retrieve event reports using serial or Ethernet communications links.



Retrofit Replacement Kits

Easily replace existing motor bus transfer protection with the SEL-700BT and the applicable mounting kit. These kits provide everything needed to replace many existing relays with the SEL-700BT. No cutting or drilling is required when you use the optional mounting kits. Replacement of existing protection is quick and easy.



SEL-700BT Specifications

General	
Display	5-inch color touchscreen display, 800 × 480 pixels
AC Current Inputs	5 A or 1 A phase and 5 A or 1 A neutral
AC Voltage Inputs	300 Vac continuous, 600 Vac for 10 seconds
Output Contacts	The relay supports Form A, B, and C outputs.
Optoisolated Control Inputs	DC/AC control signals: 250, 220, 125, 110, 48, or 24 V As many as 26 inputs are allowed in ambient temperatures of 85°C (185°F) or less.
Frequency and Phase Rotation	System frequency: 50, 60 Hz Phase rotation: ABC, ACB Frequency tracking: 15–70 Hz (requires ac voltage inputs)
Communications Protocols	SEL (Fast Meter, Fast Operate, and Fast SER), EtherNet/IP, Modbus TCP/IP, Modbus RTU, DNP3, FTP, IIRIG-B, Telnet, the Simple Network Time Protocol (SNTP), IEC 61850 Edition 2, IEC 60870-5-103, software-based IEEE 1588 PTP, PRP for dual-Ethernet models, MIRRORRED BITS communications, and IEEE C37.118-2005 (synchrophasors).
Optional Communications and I/O Cards	Serial communications card (EIA-232/-485) 3 digital inputs (DI), 4 digital outputs (DO), 1 4–20 mA analog output (AO) 4 DI, 4 DO 8 DO 8 DI 14 DI 4 DI, 3 DO (2 Form C, 1 Form B) 4 analog inputs (AI)/4 AO 10 RTD inputs
Language Support	English and Spanish
Power Supply	110–250 Vdc or 110–240 Vac Input voltage range: 85–275 Vdc or 85–264 Vac 24–48 Vdc Input voltage range: 19.2–60 Vdc
Operating Temperature	–40° to +85°C (–40° to +185°F) Note: Front-panel display contrast is impaired for temperatures below –20°C (–4°F) and above +70°C (+158°F).
Certifications	To view certifications for the SEL-700BT, please visit selinc.com/company/certifications .

SCHWEITZER ENGINEERING LABORATORIES

Making Electric Power Safer, More Reliable, and More Economical
+1.509.332.1890 | info@selinc.com | selinc.com

© 2020 by Schweitzer Engineering Laboratories, Inc.
PF00665 • 20201030

